

00/2005-10



# Engine V1100



UK



**workshop**manual



Cod. 8140898

INTRODUCTION



**SUMMARY**

0.1. INTRODUCTION ..... 3  
0.1.1. FOREWORD ..... 3  
0.1.2. REFERENCE MANUALS ..... 4  
0.1.3. ABBREVIATIONS/SYMBOLS/CONVENTIONS ..... 5



## 0.1. INTRODUCTION

### 0.1.1. FOREWORD

This manual provides the information required for normal servicing.

This publication is intended for use by **Moto Guzzi** Dealers and their qualified mechanics; many concepts have been omitted on purpose as their inclusion would be superfluous. Since complete mechanical explanations have not been included in this manual, the reader must be familiar with basic notions of mechanics, as well as with basic repair procedures. Without such familiarity, repairs and checks could be ineffective and even hazardous. Since the repair and vehicle check instructions are not exhaustive, special care must be taken to avoid damage and injury. **Moto Guzzi s.p.a.** undertakes to constantly improve the design of its products and their literature to ensure that the customer is satisfied of the product. The main technical modifications and changes in repair procedures are communicated to all **Moto Guzzi** dealers and agencies world-wide. Such modifications will be entered in subsequent editions of the manual. Should you need assistance or clarifications about the inspection and repair procedures, please contact the **Moto Guzzi** SERVICE DEPT., they will be glad to give you any information on the matter, or supply you with any detail on updates and technical changes applied to the vehicle.

**Moto Guzzi s.p.a.** reserves the right to make changes to its products at any time, barring any such changes as may alter the essential features of a product as specified in the relevant manual.

All rights of storage using electronic means, reproduction and total or partial adaptation, whatever the means adopted, are reserved in all countries.

Third parties' products are only mentioned for information purposes, and constitute no engagement.

**Moto Guzzi s.p.a.** is not liable in any way for the performance or use of these products.

For further details, see (REFERENCE MANUALS).

First edition: October 2005

Produced and printed by:

**VALLEY FORGE DECA**  
Ravenna, Modena, Torino

#### **DECA S.r.l.**

Registered Office and Administrative Headquarter  
via Vincenzo Giardini, 11 - 48022 Lugo (RA) - Italy  
Tel. +39 - 0545 216611  
Fax +39 - 0545 216610  
E-mail: [deca@vftis.spx.com](mailto:deca@vftis.spx.com)  
[www.vftis.com](http://www.vftis.com)

On behalf of:







#### **Moto Guzzi s.p.a.**

via E.V. Parodi, 57- 23826 Mandello del Lario (Lecco) - Italy  
Tel. +39 – 0341 - 709111  
Fax +39 – 0341 - 709220  
[www.motoguzzi.it](http://www.motoguzzi.it)  
[www.servicemotoguzzi.com](http://www.servicemotoguzzi.com)









0.1.2. REFERENCE MANUALS













PARTS CATALOGUES

guzzi part# (description)
GU077_00       







OWNER'S MANUALS

guzzi part# (description)
05.90.00.30      
05.90.00.31 







CHASSIS WORKSHOP MANUAL

guzzi part# (description)
8140856 
8140857 
8140858 
8140859 
8140860 
8140861 
8CM0077     
8CM0078 

ENGINE WORKSHOP MANUAL

guzzi part# (description)
8140894 
8140895 
8140896 
8140897 
8140898 
8140899 

CD FOR THE NETWORK

guzzi part# (description)
8CM0093     
8CM0094 

**0.1.3. ABBREVIATIONS/SYMBOLS/CONVENTIONS**

#	= number
<	= less than
>	= greater than
≤	= less than or equal to
≥	= more than or equal to
~	= approximately
∞	= infinity
°C	= degrees Celsius (centigrade)
°F	= degrees Fahrenheit
±	= plus or minus
a.c	= alternating current
A	= Ampere
Ah	= Ampere per hour
API	= American Petroleum Institute
AT	= high voltage
AV/DC	= Anti-Vibration Double Countershaft
bar	= pressure measurement (1 bar = 100 kPa)
d.c.	= direct current
cc	= cubic centimetres
CO	= carbon monoxide
CPU	= Central Processing Unit
DIN	= German industrial standards (Deutsche Industrie Norm)
DOHC	= Double Overhead Camshaft
ECU	= Electronic Control Unit
rpm	= revolutions per minute
HC	= unburnt hydrocarbons
ISC	= Idle Speed Control
ISO	= International Standardisation Organisation
kg	= kilograms
kgm	= kilogram metre (1 kgm = 10 Nm)
km	= kilometres
km/h	= kilometres per hour
kΩ	= kilo Ohm
kPa	= kiloPascal (1 kPa = 0.01 bar)
KS	= clutch side (from the German "Kupplungsseite")
kW	= kilowatt
l	= litres
LAP	= racetrack lap
LED	= Light Emitting Diode
LEFT SIDE	= left side
m/s	= metres per second
max	= maximum
mbar	= millibar (1 mbar = 0.1 kPa)
mi	= miles
MIN	= minimum
MPH	= miles per hour
MS	= flywheel side (from the German "Magnetoseite")
MΩ	= MegaOhm
N.A.	= Not Available
N.O.M.M.	= Motor Octane Number
N.O.R.M.	= Research Octane Number
Nm	= Newton metre (1 Nm = 0.1 kgm)
Ω	= ohm
PICK-UP	= pick-up
BDC	= Bottom Dead Centre
TDC	= Top Dead Centre
PPC	= Pneumatic Power Clutch
RIGHT SIDE	= right side
SAE	= Society of Automotive Engineers
SAS	= Secondary Air System

<b>TEST</b>	= diagnostic check
<b>T.B.E.I.</b>	= crown-head Allen screw
<b>T.C.E.I.</b>	= cheese-head Allen screw
<b>T.E.</b>	= hexagonal head
<b>T.P.</b>	= flat head screw
<b>TSI</b>	= Twin Spark Ignition
<b>UPSIDE- DOWN</b>	= inverted fork
<b>V</b>	= volt
<b>W</b>	= watt
<b>Ø</b>	= diameter

GENERAL INFORMATION

1



**SUMMARY**

1.1. STRUCTURE OF THE MANUAL ..... 3  
1.1.1. CONVENTIONS USED IN THE MANUAL ..... 3  
1.1.2. SAFETY WARNINGS ..... 4  
1.2. GENERAL RULES ..... 5  
1.2.1. BASIC SAFETY RULES ..... 5  
1.3. DANGEROUS ELEMENTS ..... 8  
1.3.1. WARNINGS ..... 8  
1.4. RUNNING-IN ..... 11  
1.4.1. RUNNING-IN ..... 11  
1.5. POSITION OF THE SERIAL NUMBERS ..... 12  
1.5.1. POSITION OF THE SERIAL NUMBERS ..... 12





## 1.1. STRUCTURE OF THE MANUAL

### 1.1.1. CONVENTIONS USED IN THE MANUAL

- This manual is divided in sections and subsections, each covering a set of the most significant components. Refer to the index of sections when consulting the manual.
- Unless expressly specified otherwise, assemblies are reassembled by reversing the dismantling procedure.
- The terms "right" and "left" are referred to the rider seated on the vehicle in the normal riding position.
- Motorcycle operation and basic maintenance are covered in the "OWNER'S MANUAL".

In this manual any variants are identified with these symbols:

-  optional
-  catalytic version
- all versions
- MP national certification
- SF European certification (EURO 1 limits)

### VERSION:

 Italy	 Greece	 Malaysia
 United Kingdom	 Holland	 Chile
 Austria	 Switzerland	 Croatia
 Portugal	 Denmark	 Australia
 Finland	 Japan	 United States of America
 Belgium	 Singapore	 Brazil
 Germany	 Slovenia	 South Africa
 France	 Israel	 New Zealand
 Spain	 South Korea	 Canada

**1.1.2. SAFETY WARNINGS**

The symbols and warnings used throughout this manual have the following meanings:



**Safety warning.** This symbol appears, whether in the manual or on the vehicle itself, to indicate a personal injury hazard. Non-compliance with the indications given in the messages preceded by this symbol may result in serious risks for your and other people's safety and for the vehicle!

**DANGER**

Indicates a potential hazard which may result in serious injury or even death.

**WARNING**

Indicates a potential hazard which may result in minor personal injury or damage to the vehicle.

**NOTE** The word "NOTE" in this manual identifies important information or instructions.

## 1.2. GENERAL RULES

### 1.2.1. BASIC SAFETY RULES

#### CARBON MONOXIDE

Should it be necessary to perform some operations with the vehicle running, make sure to work outdoors or in a well-aerated room.

Avoid starting the engine indoors.

In case you are working indoors, use a gas exhaust system.



#### DANGER

Exhaust gases contain carbon monoxide, which is extremely toxic if inhaled and may cause loss of consciousness or even lead to death.

#### FUEL



#### DANGER

The fuel used to operate engines is highly flammable and becomes explosive under particular conditions.

Refuelling and engine servicing should take place in a well-ventilated area with the engine stopped. Do not smoke when refuelling or in the proximity of sources of fuel vapours, avoid flames, sparks and any element that could ignite fuel or provoke explosions.

**DO NOT DISPOSE OF FUEL IN THE ENVIRONMENT.**

**KEEP AWAY FROM CHILDREN.**

#### HIGH-TEMPERATURE COMPONENTS

The engine and the components of the exhaust system become very hot and remain hot for some time after the engine has been stopped.

Before handling these components, wear insulating gloves or wait until the engine and the exhaust system have cooled down.

#### USED GEARBOX AND FORK FLUIDS



#### DANGER

Wear latex gloves when servicing.

Gearbox fluid may cause serious damage to the skin if handled daily and for long periods.

Wash your hands carefully after use.

Take it to the filling station where you usually buy it or to an oil salvage centre.

Wear latex gloves when servicing.

**DO NOT DISPOSE OF FLUID IN THE ENVIRONMENT.**

**KEEP AWAY FROM CHILDREN.**

#### BRAKE FLUID



#### WARNING

When handling the brake fluid, take care not to spill it on the plastic, rubber or painted parts, since it can damage them. When carrying out the maintenance operations on the braking system, use a clean cloth to cover these parts.

Always wear safety goggles when working on the braking system.

The brake fluid is highly irritant. Avoid contact with your eyes.

If the brake fluid gets in contact with your eyes, carefully wash them with fresh water and immediately seek medical advice.

**KEEP AWAY FROM CHILDREN.**



## HYDROGEN AND BATTERY FLUID

**DANGER**

The battery electrolyte is a toxic, caustic substance containing sulphuric acid and thus able to cause severe burns in case of contact with the skin.

Always wear tight gloves and protective clothes when handling this fluid.

In case of contact with skin, rinse with plenty of fresh water.

Always use a protection for your eyes since even a very small amount of the battery fluid can cause blindness. In the event of contact with your eyes, carefully wash them with water for fifteen minutes and then consult immediately an eye specialist.

Should you accidentally drink some fluid, drink abundant water or milk, then drink magnesia milk or vegetable oil and immediately seek medical advice.

The battery gives off explosive gases and must be kept away from flames and sources of ignition or heat; do not smoke near the battery.

Make sure the room is well-aerated when servicing or recharging the battery.

**KEEP AWAY FROM CHILDREN.**

The battery fluid is corrosive.

Do not spill it, especially on plastic parts.

Make sure that the electrolyte acid is suitable for the type of battery used.

**GENERAL PRECAUTIONS AND INFORMATION**

Follow these instructions closely when repairing, disassembling or reassembling the motorcycle or its components.

**DANGER**

Using bare flames is strictly forbidden when working on the motorcycle. Before servicing or inspecting the motorcycle: stop the engine and remove the key from the ignition switch; allow for the engine and exhaust system to cool down; where possible, lift the motorcycle using adequate equipment placed on firm and level ground. Be careful of any parts of the engine or exhaust system which may still be hot to the touch to avoid scalds or burns.

Do not put any vehicle parts into your mouth: vehicle components are not edible and some of them are harmful or even toxic.

Unless expressly specified otherwise, assemblies are reassembled by reversing the dismantling procedure. Where a procedure is cross-referred to relevant sections in the manual, proceed sensibly to avoid disturbing any parts unless strictly necessary. Do not polish matt-painted surfaces with polishing paste.

Never use fuel instead of solvent to clean the motorcycle.

Do not clean any rubber or plastic parts or the seat with alcohol, petrol or solvents. Clean with water and mild detergent.

Always disconnect the battery negative (-) lead before soldering any electrical components.

When two or more persons service the same motorcycle together, special care must be taken to avoid personal injury.

For further warnings, see (DANGEROUS ELEMENTS)

**BEFORE DISASSEMBLING ANY COMPONENTS**

- Clean off all dirt, mud, and dust and clear any foreign objects from the vehicle before disassembling any components.
- Use the model-specific special tools where specified.

**DISASSEMBLING THE COMPONENTS**

- Never use pliers or similar tools to slacken and/or tighten nuts and bolts. Always use the suitable spanner.
- Mark all connections (hoses, wiring, etc.) with their positions before disconnecting them. Identify each connection using a distinctive symbol or convention.
- Mark each part clearly to avoid confusion when refitting.
- Thoroughly clean and wash any components you have removed using a detergent with low flash point.
- Mated parts should always be refitted together. These parts will have seated themselves against one another in service as a result of normal wear and tear and should never be mixed up with other similar parts on refitting.
- Certain components are matched-pair parts and should always be replaced as a set.
- Keep away from heat sources.

## REASSEMBLING THE COMPONENTS

**DANGER**

Never reuse a circlip or snap ring. These parts must always be renewed once they have been disturbed.

When fitting a new circlip or snap ring, take care to move the open ends apart just enough to allow fitment to the shaft.

Make it a rule to check that a newly-fitted circlip or snap ring has located fully into its groove.

Never clean a bearing with compressed air.

**NOTE** All bearings must rotate freely with no hard spots or noise. Replace any bearings that do not meet these requirements.

- Use GENUINE **Moto Guzzi** spare parts only.
- Use the specified lubricants and consumables.
- Where possible, lubricate a part before assembly.
- When tightening nuts and bolts, start with the largest or innermost nut/bolt and observe a cross pattern. Tighten evenly, in subsequent steps until achieving the specified torque.
- Replace any self-locking nuts, gaskets, seals, circlips or snap rings, O-rings, split pins, bolts and screws which have a damaged thread.
- Lubricate the bearings abundantly before assembly.
- Make it a rule to check that all components you have fitted are correctly in place.
- After repairing the motorcycle and after each service inspection, perform the preliminary checks, and then test ride the motorcycle in a private estate area or in a safe area away from traffic.
- Clean all mating surfaces, oil seal edges and gaskets before assembly. Apply a thin layer of lithium grease along the edges of oil seals. Fit oil seals and bearings with the marking or serial number facing outwards (in view).

## ELECTRICAL CONNECTORS

To disconnect the electrical connectors, follow the procedures below. Failure to comply with these procedures may lead to irreparable damage to the connector and the wiring as well.

If present, press the special safety hooks.

**WARNING**

Do not pull cables to disconnect the two connectors.

- Grasp the two connectors and disconnect them by pulling them in the two opposite directions.
- In case of dirt, rust, moisture, etc., thoroughly clean the inside of the connectors with compressed air.
- Make sure that the cables are correctly fitted inside the connector terminals.

**NOTE** The two connectors have just one correct positioning. Make sure to position them in the right direction.

- Then fit the two connectors. Make sure they are correctly coupled (a click will be heard if hooks are present).

## TIGHTENING TORQUE SETTINGS

**DANGER**

Always remember that the tightening torque settings of all wheel, brake, wheel shaft and other suspension parts fasteners play a fundamental role to ensure vehicle safety. Make sure that these values are always within the specified limits.

Check fastening parts tightening torque settings at regular intervals. Upon reassembly, always use a torque wrench.

Failure to comply with these recommendations could lead to the loosening and detachment of one of these parts with a consequent locking of the wheel or other serious troubles affecting the vehicle manoeuvrability, and thus the risk of falls and serious injuries or death.

### 1.3. DANGEROUS ELEMENTS

#### 1.3.1. WARNINGS

#### FUEL

**DANGER**

The fuel used to operate engines is highly flammable and becomes explosive under particular conditions.

Refuelling and engine servicing should take place in a well-ventilated area with the engine stopped. Do not smoke when refuelling or in the proximity of sources of fuel vapours, avoid flames, sparks and any element that could ignite fuel or provoke explosions.

Take care not to spill fuel out of the filler, or it may ignite when in contact with hot engine parts.

In the event of accidental fuel spillage, make sure the affected area is fully dry before starting the engine. Fuel expands from heat and when left under direct sunlight.

Never fill the fuel tank up to the brim. Tighten the filler cap securely after each refuelling.

Avoid contact with skin. Do not inhale vapours. Do not swallow fuel. Do not transfer fuel between different containers using a hose.

**DO NOT DISPOSE OF FUEL IN THE ENVIRONMENT.**

**KEEP AWAY FROM CHILDREN.**

Use only premium grade unleaded petrol, min. O.N. 95 (RON) and 85 (MON).

#### LUBRICANTS

**DANGER**

A good lubrication ensures the vehicle safety.

Failure to keep the lubricants at the recommended level or the use of a non-suitable new and clean type of lubricant can lead to the engine or gearbox seizure, thus causing serious accidents, personal injury or even death.

Gearbox fluid may cause serious damage to the skin if handled daily and for long periods.

Wash your hands carefully after use.

Do not dispose of oil in the environment.

Take it to the filling station where you usually buy it or to an oil salvage centre.

**WARNING**

When filling the vehicle with this oil, take care not to spill it out. Immediately clean spilt oil, or it might damage the vehicle paintwork.

In case of contact with oil, the tyre surface will become very slippery, thus becoming a serious danger for your safety.

In case of leaks, do not use the vehicle. Check and trace the cause of leaks and proceed to repair.

#### ENGINE OIL

**DANGER**

Engine oil may cause serious damage to the skin if handled daily and for long periods.

Wash your hands carefully after use.

Do not dispose of oil in the environment.

Dispose of engine oil through the nearest waste oil reclamation firm or through the supplier.

Wear latex gloves when servicing.

#### FRONT FORK FLUID

**DANGER**

Front suspension response can be modified to a certain extent by changing damping settings and/or selecting a particular grade of oil. Standard oil: SAE 20 W. Choose suitable viscosity grades according to the desired set-up (choose SAE 5W for a softer suspension, 20W for a stiffer suspension).

The two grades can also be mixed in varying solutions to obtain the desired response.

## Engine V1100

**BRAKE FLUID**

**NOTE** This vehicle is fitted with front and rear disc brakes. Each braking system is operated by an independent hydraulic circuit. The information provided below applies to both braking systems.

**DANGER**

Do not use the vehicle in case brakes are worn out or do not work properly. The brakes are the parts that most ensure your safety and for this reason they must always be perfectly working. Failure to comply with these recommendations will probably lead to a crash or an accident, with a consequent risk of personal injury or death.

A wet surface reduces brakes efficiency.

**DANGER**

In case of wet ground the braking distance will be doubled, since both brakes and tyre grip on the road surface are extremely reduced by the water present on the road surface.

Any water on brakes, after washing the vehicle or driving on a wet road surface or crossing puddles or gips, can wet brakes so as to greatly reduce their efficiency.

Failure to comply with these recommendations may lead to serious accidents, with a consequent risk of severe personal injuries or death.

Brakes are critical safety components. Do not ride the vehicle in case brakes are not working at their best.

Check for brakes proper operation before every trip.

Brake fluid is an irritant. Avoid contact with eyes or skin.

In the event of accidental contact, wash affected body parts thoroughly. In the event of accidental contact with eyes, contact an eye specialist or seek medical advice.

**DO NOT RELEASE BRAKE FLUID INTO THE ENVIRONMENT.**

**KEEP AWAY FROM CHILDREN.**

When handling brake fluid, take care not to spill it onto plastic or paint-finished parts or they will damage.

**DANGER**

Do not use any brake fluids other than the specified type. Never mix different types of fluids to top up level, as this will damage the braking system.

Do not use brake fluid from containers which have been kept open or in storage for long periods.

Any sudden changes in play or hardness in the brake levers are warning signs of problems with the hydraulic circuits.

Ensure that the brake discs and brake linings have not become contaminated with oil or grease. This is particularly important after servicing or inspections.

Make sure the brake lines are not twisted or worn.

Prevent accidental entering of water or dust into the circuit.

Wear latex gloves when servicing the hydraulic circuit.

**DISC BRAKES****DANGER**

The brakes are the parts that most ensure your safety and for this reason they must always be perfectly working; check them before every trip.

A dirty disc soils the pads.

Dirty pads must be replaced, while dirty discs must be cleaned with a high-quality degreaser.

Perform the maintenance operations with half the indicated frequency if the vehicle is used in rainy or dusty areas, on uneven surfaces or for racing.

Check brake pads for wear.

When the brake pads wear out, the level of the fluid decreases to automatically compensate for their wear.

The front brake fluid reservoir is located on the right handlebar, near the front brake lever.

The rear brake fluid reservoir is located under the right fairing.

Do not use the vehicle if the braking system leaks fluid.

## TYRES

**WARNING**

If tyres are excessively inflated, the vehicle will be hard, difficult and uncomfortable to ride. In addition, the roadworthiness, mainly on wet surfaces and during cornering, will be impaired. Flat tyres (insufficient pressure) can slip on the rim and make you lose the control of the vehicle. In this case too, both vehicle roadworthiness, manoeuvrability and brake efficiency will be impaired. Tyres changing, repair, maintenance and balancing must be carried out by specialised technicians using suitable equipment. When new, tyres can have a thin slippery protective coating. Drive carefully for the first kilometres (miles). Never use rubber treating substances on tyres. In particular, avoid contact with fluid fuels, leading to a rapid wear. In case of contact with oil or fuel, do not clean but change the tyres.

**DANGER**

Some of the factory-assembled tyres of this vehicle are provided with wear indicators. There are several kinds of wear indicators. For more information on how to check the wear, contact your Dealer. Visually check if the tyres are worn and in this case have them changed. If a tyre deflates while driving, stop immediately. Avoid hard brakings or moves and do not close throttles too abruptly. Slowly close the throttle grip, move to the edge of the road and use the engine brake to slow down until coming to a halt. Failure to comply with these recommendations may lead to accidents, with a consequent risk of personal injuries or death. Do not install tyres with air tube on rims for tubeless tyres and vice versa.

## Engine V1100

**1.4. RUNNING-IN****1.4.1. RUNNING-IN**

Correct engine running-in is essential to ensuring proper performance and durability.

Twisty, hilly roads are ideal for an effective running-in of engine, suspension and brakes.

During running-in, change speed.

This will allow engine parts to be alternately loaded and unloaded, allowing them to cool down when unloaded.

While it is important to put some stress on engine components during running-in, it is equally important to avoid extreme load conditions.

**WARNING**

**Only after the first 2000 km (1243 mi) of running-in is it possible to obtain the best acceleration performance from the vehicle.**

Follow these recommendations:

- Do not open the throttle completely if the speed is low, both during and after running-in.
- Until you have covered the first 100 km (62 mi), use the brakes gently and avoid harsh, prolonged braking. This ensures a correct bedding-in of the pads on the brake discs.
- During the first 1000 km (621 mi), never exceed 5000 rpm (see table).

**WARNING**

**After the first 1000 km (621 mi), carry out the checking operations indicated in the column "After running-in", see REGULAR SERVICE INTERVALS CHART, in order to avoid hurting yourself or other people and/or damaging the vehicle.**

- After the first 1000 km (621 mi) and until covering 2000 km (1243 mi), drive more briskly, varying speed and using maximum acceleration for just a few seconds, in order to ensure better coupling of the components; never exceed 6000 rpm (see table).
- After the first 2000 km (1243 mi) you may run the engine harder, however, without exceeding the maximum rpm allowed (7600 rpm).

Recommended maximum rpm	
Mileage Km (mi)	rpm
0÷1000 (621)	5000
1000÷2000 (621÷1243)	6000
Over 2000 (1243)	7600

## 1.5. POSITION OF THE SERIAL NUMBERS

### 1.5.1. POSITION OF THE SERIAL NUMBERS

These numbers are necessary for the registration of the vehicle.

**NOTE** Do not alter the identification numbers if you do not want to incur severe penal and administrative sanctions; in particular, altering the frame number voids the warranty.

### ENGINE NUMBER

The engine number is stamped on the left side, close to engine oil level plug.

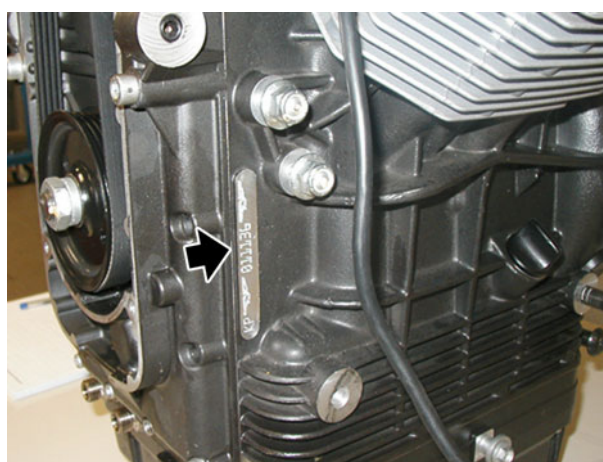

TECHNICAL INFORMATION

2





**SUMMARY**

2.1. TECHNICAL INFORMATION..... 3  
2.1.1. TECHNICAL DATA..... 3  
2.1.2. LUBRICANT TABLE..... 4  
2.1.3. TIGHTENING TORQUE SETTINGS ..... 5  
2.1.4. SPECIAL TOOLS ..... 7









Engine V1100

2.1. TECHNICAL INFORMATION

2.1.1. TECHNICAL DATA

<b>ENGINE</b>	
Type	twin-cylinder, 90° V transversal, 4-stroke engine
Number of cylinders	two
Cylinder arrangement	V, 90°
Total displacement	1064 cu cm (65 cu in)
Bore/stroke	92 x 80 mm (3.6 x 3.1 in).
Compression ratio	9.6 : 1
Starting	electric
Engine idling speed	1100 ± 100 rpm
Clutch	single plate, dry clutch with cush drive damper
Lubricating system	System under pressure, adjustment by valves and vane pump
Air filter	cartridge, dry
Cooling system	air cooled
<b>CAPACITIES</b>	
Engine oil	Engine oil and oil filter change 3600 cu. cm (219 cu in)
Gearbox fluid	500 cu cm (30.5 cu in)
Transmission fluid	380 cu cm (23.2 cu in)
<b>TIMING SYSTEM</b>	
Timing diagram:	2 valves, with rods and rocker arms
Values with inspection clearance between rocker arms and valve	intake 0.10 mm (0.0039 in.) exhaust 0.15 mm (0.0059 in.)
<b>TRANSMISSION SYSTEM</b>	
primary drive	gear, ratio: 26/35 = 1:1.3461
gearbox	Mechanic, with 6 speeds, controlled by a pedal on engine left side
overall gear ratios:	
1st gear	17/38 = 1:2.2353
2nd gear	20/34 = 1:1.7
3rd gear	23/31 = 1:1.3478
4th gear	26/29 = 1:1.1154
5th gear	31/30 = 1:0.9677
final drive	with cardan joint
ratio	12/44 = 1:3.6667
<b>FUEL SYSTEM</b>	
Type	Electronic injection (Weber – Marelli) with stepper motor
Choke	Ø 36 mm (1.417 in.)
Fuel	Premium grade unleaded petrol, minimum octane rating 95 (RON) and 85 (MON).
<b>SPARK PLUGS</b>	
Internal (long life)	NGK PMR8B
External	NGK BPR6ES
Electrode gap	0.6 – 0.7 mm (0.024 – 0.028 in.)

2.1.2. LUBRICANT TABLE

LUBRICANT	PRODUCT
Engine oil	RECOMMENDED:  Agip RACING 4T 5 W 40 As an alternative to recommended oils, top brand oils meeting or exceeding CCMC G-4 A.P.I. SG specifications can be used.
Transmission fluid	RECOMMENDED:  Agip TRUCK GEAR 80 W 90
Gearbox fluid	RECOMMENDED:  Agip ROTRA MP/S 85 W 90
Bearings and other lubrication points	RECOMMENDED:  BIMOL GREASE 481,  AUTOGREASE MP or  Agip GREASE SM2. As an alternative to recommended grease, use top brand rolling bearing grease that will resist a temperature range of -30°C to +140°C (-22°F to +284°F), with dripping point 150°C to 230°C (302°F to 446°F), high corrosion protection, good resistance to water and oxidisation.

## 2.1.3. TIGHTENING TORQUE SETTINGS

DESCRIPTION	QUANTITY	SCREW / NUT	TIGHTENING TORQUE (Nm)	Note
<b>HEAD UNIT</b>				
head taper cap	6		4	
stud bolt M8x42	4	M8	35	
adjuster	4		///	
Nut	4		8-11	
Hex.head screw DA M6x16	4	M6	6-8	
stainl.st. TBEI screw M6x25	16	M6	10	
stainl.st.flanged TBEI screw M5x16	4	M5	6-7	
oil/head temperature sensor M12x1.5	1	M12	10-12	
head temperature sensor casing M10x1.5	1	M10	10-12	
<b>TIMING UNIT</b>				
Hex.head screw DA M6x20	3	M6	8-12	
nut M18x1.5	1	M18	150	
belt tension			50	
<b>LOCKS</b>				
stud bolt M10x35	2	M10	40	
Linkage	1		42	
nut EA ZB M10x1.5	2	M10	40-42	
head bolt	1		40-42	
stud bolt M8x75	2	M8	35	
stud bolt M8x66	1	M8	35	
Hex.head screw DA M8x25	2	M8	25	
Flathead Allen screw M4x8 UNI 5933	1	M4	5	
TCEI screw M4x10	2	M4	5	
Hex.head screw DA M8x25	1	M8	25	
TCEI screw DA M6x30	2	M6	8-12	
TCEI screw DA M8x55 cl. 8.8 UNI 5931 dacromet	1	M8	23	
TCEI screw M6x16	2	M6	8-12	
TCEI screw DA M6x30	1	M6	8-12	
TCEI screw DA M6x40	2	M6	8-12	
TCEI screw DA M6x60	1	M6	8-12	
fitting M24x1.5	2	M24	40	
TCEI screw DA M6x55	1	M6	8-12	
TCEI screw DA M6x20	2	M6	8-12	
copper line nipples M18x1.5	1	M18	20	
plug with rod	2		///	
magnetic plug M10x1.5	1	M10	20	

DESCRIPTION	QUANTITY	SCREW / NUT	TIGHTENING TORQUE (Nm)	Note
<b>LUBRICATION UNIT</b>				
TCEI screw DA M8x30	4	M8	25	
drilled screw M8x1.25	1	M8	15-18	
plug M18x1.5	1	M18	40	
plug M32x1.5	1	M32	40	
<b>CRANKSHAFT UNIT</b>				
connecting rod screw	2		60-62	
nut EBFM ZB MF25x1.5	1	M25	120	
<b>FRAME UNIT ON ENGINE</b>				
TCEI screw DA M6x40	2	M6	8-12	
reduction	4		20	
<b>IGNITION UNIT</b>				
TCEI screw DA M8x45	1	M8	22	
TCEI screw DA M10x60	1	M10	see nut	
nut M10x1.5 flanged	1	M10	30	
TBEI screw DA M8x50	1	M8	///	
nut EBFM DA MF16x1.5	1	M16	80	
spark plug NGK BPR 6ES	2		20-30	
spark plug PMR8b	2		13-15	
TCEI screw M6x16	4	M6	8-12	
<b>FUEL FEED CONTROL UNIT</b>				
TCEI screw M5x12	2	M5	6-7	
stainl.st.flanged TBEI screw M5x16	2	M5	6-7	
TCEI screw DA M6x25	6	M6	8-12	
<b>GEAR SHIFT UNIT</b>				
Screws securing clutch housing to gearbox	14	M6	13	
Screws securing bearing to clutch housing	3	M6	10	
Clutch housing stop screws	1	M8	24	
Ring nut on clutch shaft	1	M22x1	100	
Neutral sensor on gearbox	1	M8x1	10	
Magnetic plug	1	M10	24	
Oil filler cap	1	M18x1.5	28	
Union for breather hose	1	M10	8	

2.1.4. SPECIAL TOOLS

Suitable special tools are necessary for correctly removing, refitting and adjusting. Unsuitable tools and/or improvised procedures could cause damages that might be avoided if the special tools are used. Following are the special tools especially designed for this vehicle. If necessary, request the general special tools.

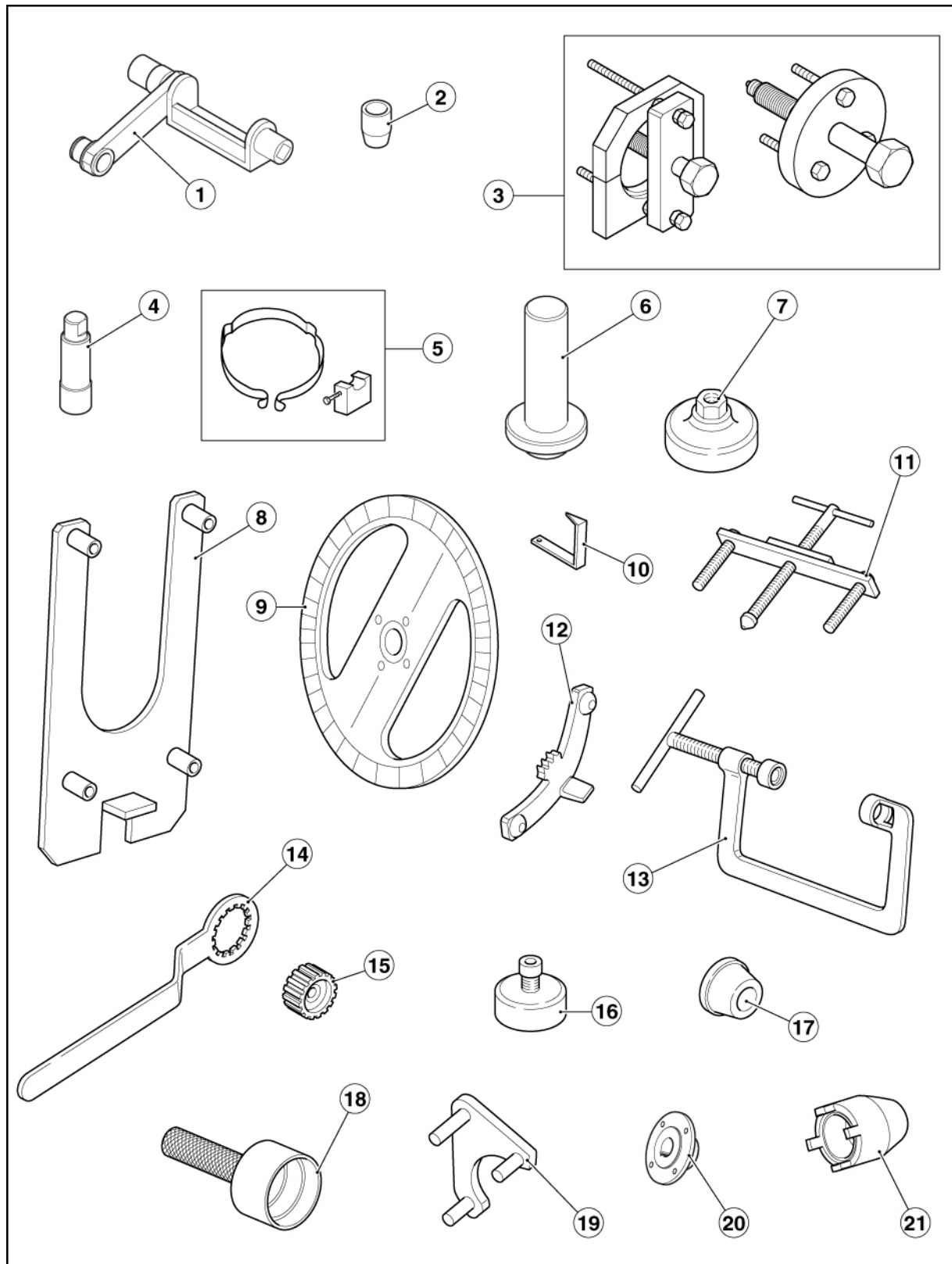

Pos.	Description	Part no.
1	Belt tensioning tool	05.94.86.30
2	Front cover installation cone	05.91.17.30
3	Gearbox opening tool	05.91.25.30
4	Tool for removing the internal spark plug	05.90.19.30
5	Piston ring compression tool	05.92.80.30
6	Timing cover seal drift	05.92.72.30
7	Wrench for removing the cover on sump and filter	01.92.91.00
8	Support for gearbox	14.92.96.00
9	Degree wheel for checking timing	19.92.96.00
10	Index for checking timing	17.94.75.60
11	Tool for removing flange on flywheel side	12.91.36.00
12	Tool for locking the flywheel and the starter gear	12.91.18.01
13	Tool for removing and installing the valves	10.90.72.00
14	Tool for locking the clutch body	30.91.28.10
15	Clutch installing tool	30.90.65.10
16	Tool for installing the seal on flywheel-side flange	14.92.71.00
17	Tool for assembling flywheel-side flange with seal onto crankshaft	12.91.20.00
18	Tool for installing the seal on flywheel-side flange	19.92.71.00
19	Tool for retaining camshaft gear	14.92.73.00
20	Hub for degree wheel	65.92.84.00
21	Tool for removing the clutch hub	05.91.26.30

ENGINE

3



## SUMMARY

3.1.	REMOVING THE ACCESSORIES .....	3
3.1.1.	REMOVING THE STARTER MOTOR .....	3
3.1.2.	REMOVING THE BLOW-BY SYSTEM .....	4
3.2.	GENERATOR .....	6
3.2.1.	REMOVING THE GENERATOR .....	6
3.2.2.	INSTALLATION .....	10
3.3.	TIMING SYSTEM .....	14
3.3.1.	REMOVAL AND INSTALLATION .....	14
3.3.2.	TECHNICAL DATA .....	18
3.3.3.	TIMING .....	19
3.3.4.	MEASURING THE SENSOR GAP .....	21
3.4.	OIL PUMP .....	23
3.4.1.	REMOVING THE OIL PUMP .....	23
3.5.	HEADS .....	24
3.5.1.	REMOVING THE HEAD COVERS .....	24
3.5.2.	REMOVING THE HEADS .....	25
3.5.3.	CHECKING THE COMPONENTS .....	30
3.5.4.	REASSEMBLING THE HEADS .....	32
3.6.	CYLINDERS AND PISTONS .....	37
3.6.1.	REMOVAL, CHECK AND INSTALLATION .....	37
3.7.	FLYWHEEL .....	42
3.7.1.	REMOVAL, CHECK AND REASSEMBLY .....	42
3.8.	CRANKSHAFT AND CONNECTING RODS .....	44
3.8.1.	REMOVAL .....	44
3.8.2.	CHECK .....	46
3.8.3.	REASSEMBLY .....	49
3.9.	OIL SUMP .....	50
3.9.1.	REMOVAL, CHECK AND REASSEMBLY .....	50

**Engine V1100****3.1. REMOVING THE ACCESSORIES****3.1.1. REMOVING THE STARTER MOTOR**

- Loosen and remove the two screws and collect the washers.



- Slide out the starter motor.



### 3.1.2. REMOVING THE BLOW-BY SYSTEM

- Loosen the oil recovery line fitting and remove the oil recovery line from the crankcase.



- Remove the tie.



- Release the two clamps retaining the oil breather line.



- Remove the two oil breather lines.



**Engine V1100**

- Loosen and remove the oil recovery line positioning screw.
- Release the oil recovery line.



- Remove the complete blow-by system.

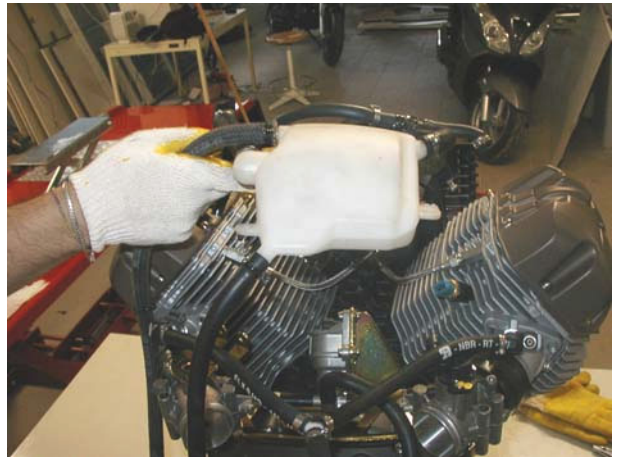



## 3.2. GENERATOR

### 3.2.1. REMOVING THE GENERATOR

- Loosen and remove the six screws and collect the bushes.



- Remove the cover.

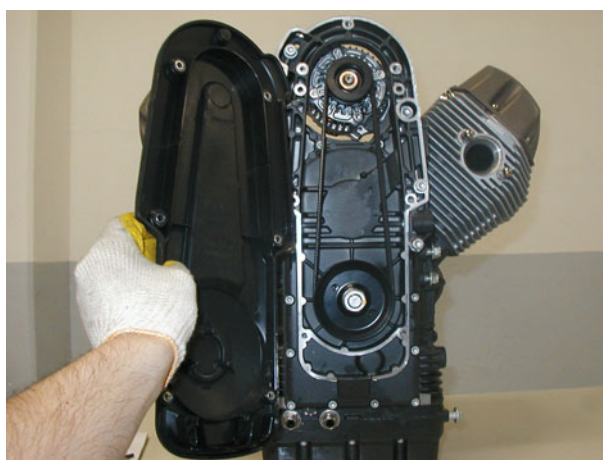

- Release and remove the eight screws.

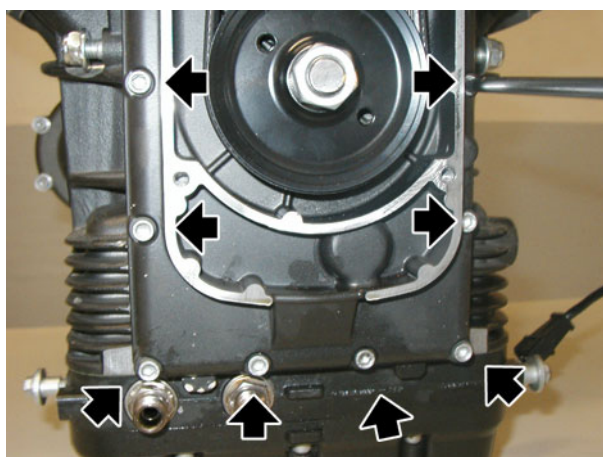

## Engine V1100

- Release and remove the two screws.



- Loosen the nut and collect the screw.

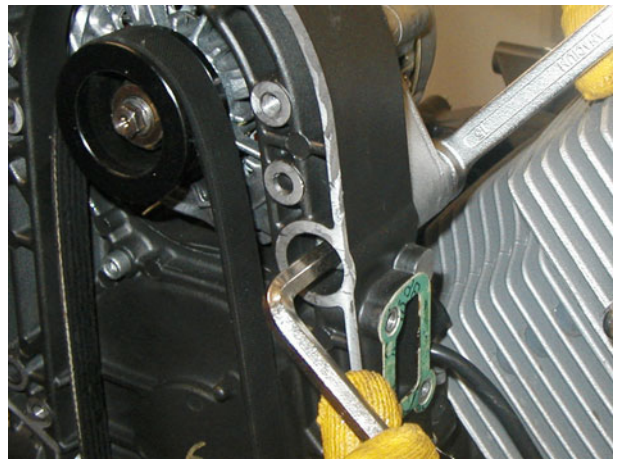

- Loosen the screw.



- Loosen the nut and release the adjuster, so that generator can slide down.

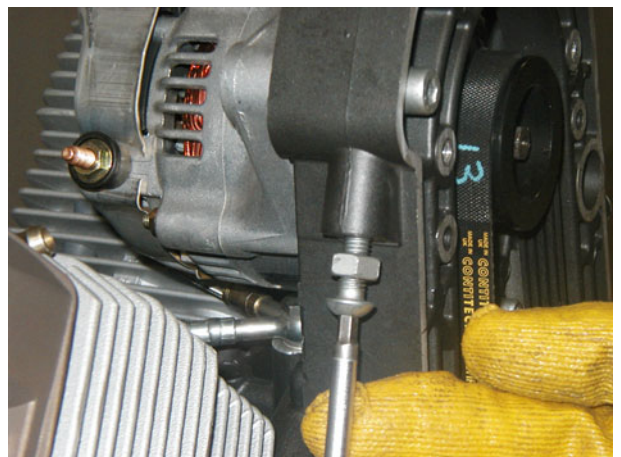



- Completely unscrew and remove the screw.

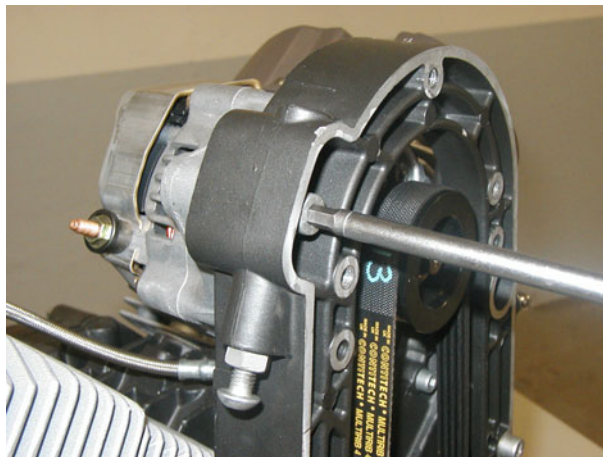

- Remove the belt and the generator complete with pulley.



- Using an air gun, loosen and remove the nut and collect the spacer.
- Slide out the lower pulley.



- Release and remove the two screws.

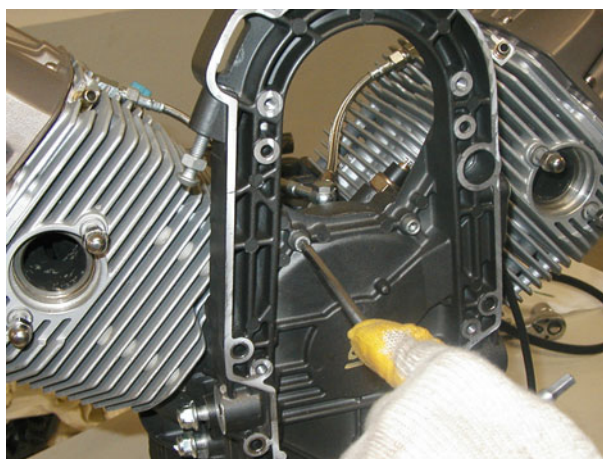

**Engine V1100**

- Remove the generator subframe.
- Remove the seal, if necessary.





### 3.2.2. INSTALLATION

- If previously removed, change the seal using the timing cover seal drift (part no. 05.92.72.30).



- Change the gasket and position the generator subframe, using the front cover insertion cone (part no. 05.91.17.30).
- Remove the front cover insertion cone (part no. 05.91.17.30).



- Tighten the two screws.

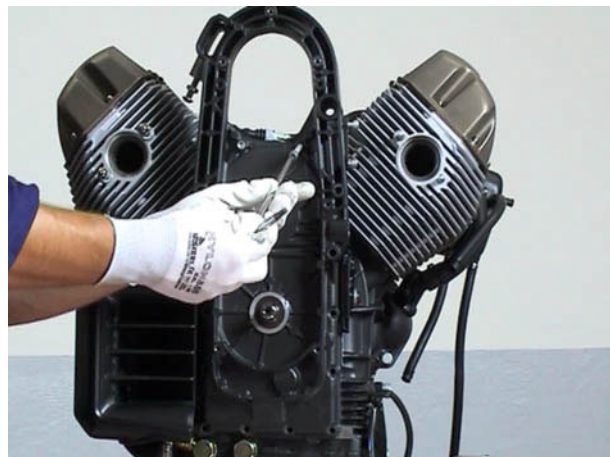

- Tighten the eight lower screws.



## Engine V1100

- Tighten the ten screws; proceed in steps and in a cross pattern.

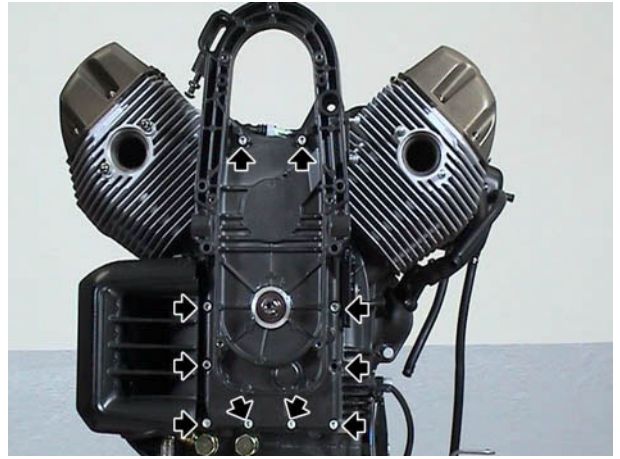

- Position the lower pulley and the spacer.
- Tighten the nut to the specified torque.

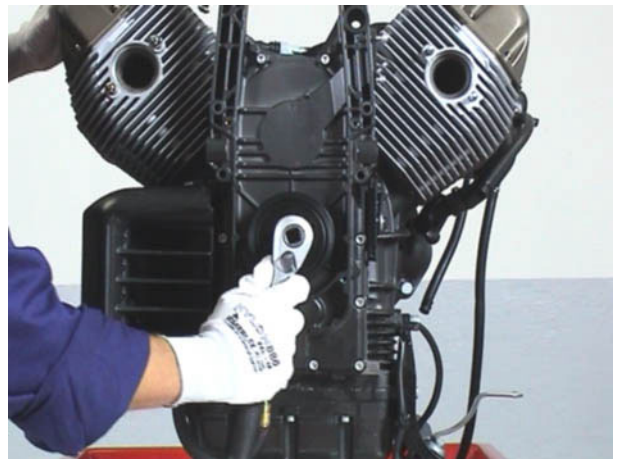

- Position the generator and the timing belt.

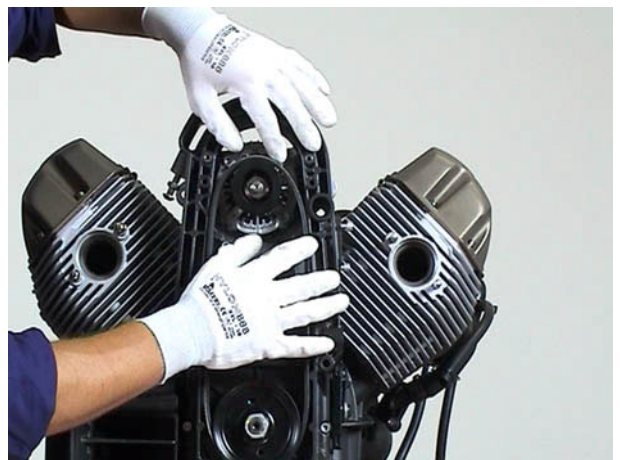

- Position the screw and tighten it.



- Position the screw and nut and tighten them.



- Using the belt tensioning tool, tension the belt to the specified value and tighten the adjuster.
- Remove the belt tensioning tool.

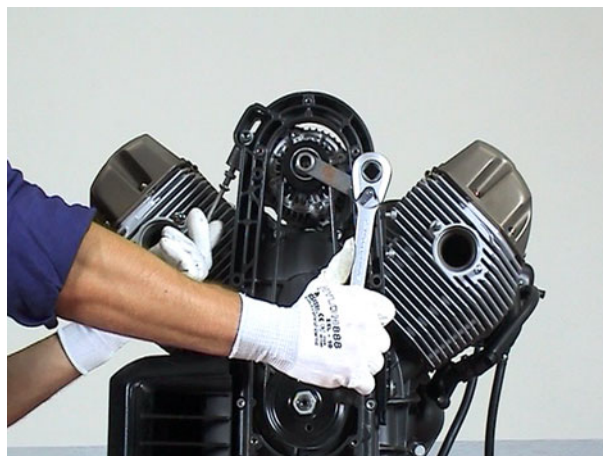

- Tighten the lock nut.

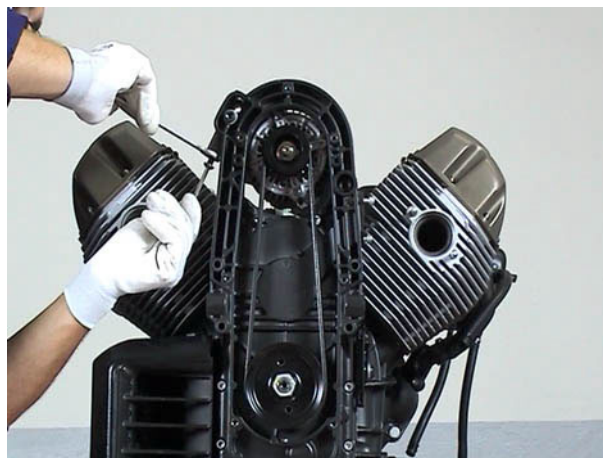

- Tighten the generator retaining screws.





- Tighten the four screws; proceed in steps and in a cross pattern.

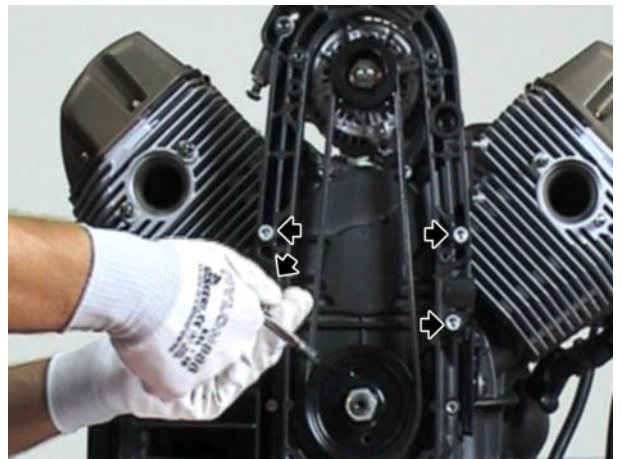

- Fit the timing cover.



- Tighten the five screws; proceed in steps and in a cross pattern.



### 3.3. TIMING SYSTEM

#### 3.3.1. REMOVAL AND INSTALLATION

##### REMOVAL

- Remove the engine from the frame, see chassis manual, see (REFERENCE MANUALS).
- Remove the generator following the instructions given in (REMOVAL).
- Remove both heads, see (REMOVING THE HEADS).
- Mark the timing references to be restored upon reassembly.

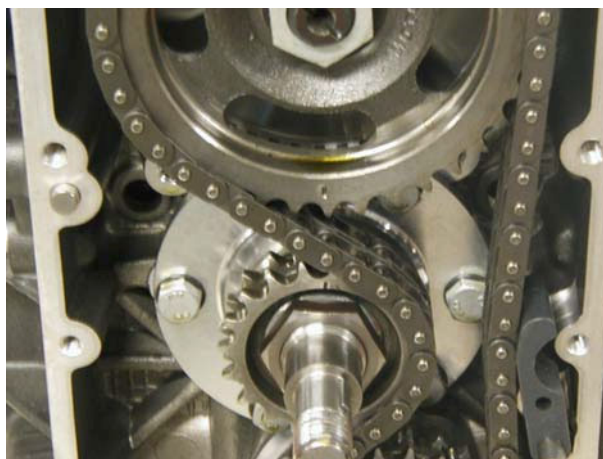

- Using the suitable tool (part no. 12.91.18.01) lock the starter gear.



- Loosen the central nut securing the camshaft gear and collect the washer.

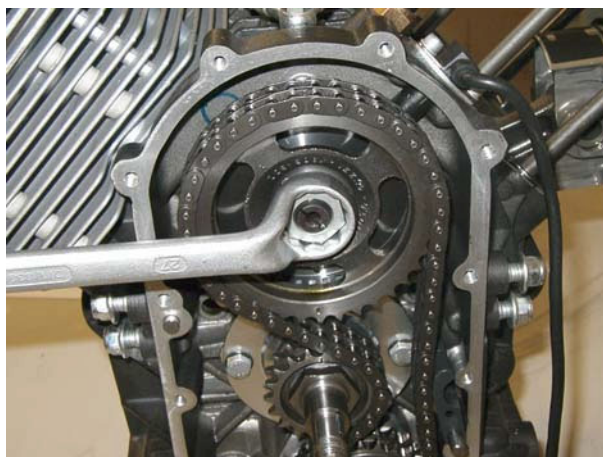



## Engine V1100

- Remove the key.

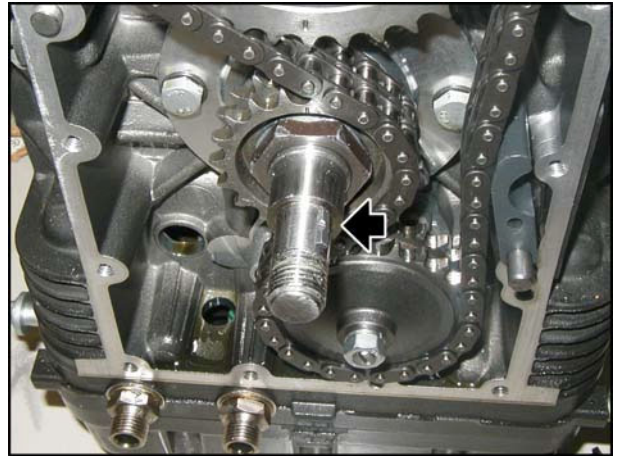

- Loosen and remove the central nut securing the timing drive gear on the crankshaft and collect the washer.

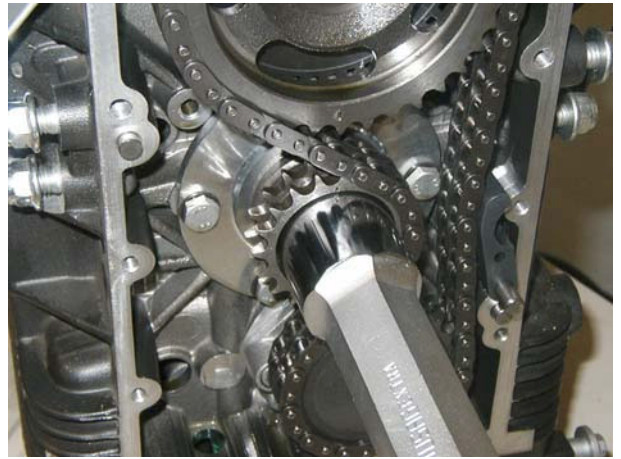

- Loosen and remove the nut and collect the washer.



- Slide out the chain tensioner and collect the spring.
- Remove the three gears with the chain.



- Slide out the pick-up ring and collect the dowel.



- Loosen and remove the three screws and collect the washers.

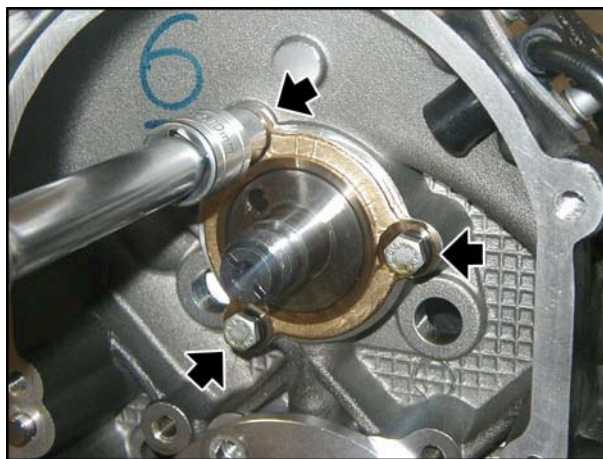

- Slide out the flange.



- Slide out the tappets from their seats on either side.



**Engine V1100**

- Slide out the camshaft.

**REASSEMBLY**

**NOTE** For refitting the timing system, suitably heat the engine with a heater to be able to correctly fit the camshaft avoiding damages.

- Follow the removal instructions in reverse order.



### 3.3.2. TECHNICAL DATA

Timing data:

#### INTAKE

A Opens at 22° before TDC  
D Closes at 54° after BDC

#### EXHAUST

C Opens at 52° before BDC  
B Closes at 24° before TDC

Intake valve clearance 0.10 mm (0.0039 in.)  
Exhaust valve clearance 0.15 mm (0.0059 in.)

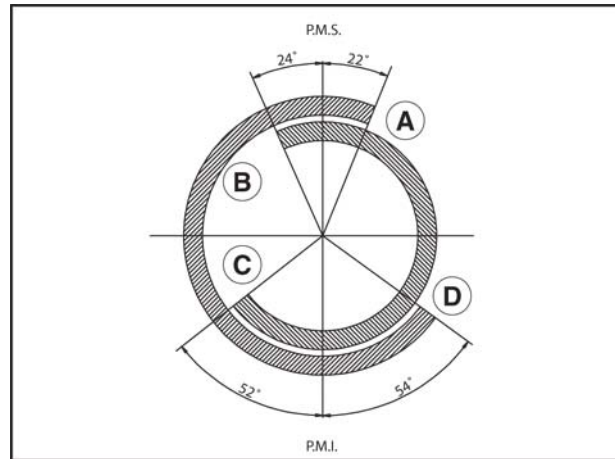

#### DIAMETER OF THE CAMSHAFT SUPPORTS AND RELEVANT SEATS ON CRANKCASE

	SHAFT SUPPORT Ø mm (inch)	CRANKCASE SEATS Ø mm (inch)	ASSEMBLY CLEARANCE mm (inch)
Timing side	47.000÷46.984 (1.85039 ÷ 1.84976)	47.025÷47.050 (1.85137 ÷ 1.85236)	0.025÷0.066 (0.00098 ÷ 0.00260)
Flywheel side	32.000÷31.984 (1.25984 ÷ 1.25921)	32.025÷32.050 (1.26082 ÷ 1.26181)	

#### TAPPET-TO-SEAT ON CRANKCASE COUPLING

	SEATS Ø mm (inch)	TAPPETS OUTER Ø mm (inch)	ASSEMBLY CLEARANCE mm (inch)
Production	22.021÷22.000 (0.86697 ÷ 0.86614)	21.996÷21.978 (0.86598 ÷ 0.86527)	0.004÷0.043 (0.00016 ÷ 0.00169)
Oversized on Ø 0.05 mm (0.00196 in.)	22.071÷22.050 (0.86893 ÷ 0.86811)	22.046÷22.028 (0.86795 ÷ 0.86724)	0.004÷0.043 (0.00016 ÷ 0.00169)
Oversized on Ø 0.10 mm (0.00394 in.)	22.121÷22.100 (0.87090 ÷ 0.87008)	22.096÷22.078 (0.86992 ÷ 0.86921)	0.004÷0.043 (0.00016 ÷ 0.00169)

## Engine V1100

## 3.3.3. TIMING

To check the timing proceed as follows:

- Set clearance between rocker arms and valves to mm 1.5 (0.059 in);
- Set degree wheel hub (part no. 65.92.84.00) with degree wheel (part no. 19.92.96.00) onto crankshaft groove, insert the spacer and secure to crankshaft using the nut.
- Secure the index (part no. 17.94.75.60) to the threaded hole to the left of the crankcase using a screw.
- Fit a dial gauge support to left cylinder external spark plug, and fit a dial gauge on the support.
- Turn the crankshaft until left cylinder piston is at top dead centre (with valves closed).
- Reset the dial gauge and ensure that the reference marks (on timing gears and engine sprocket) are perfectly in line; look through the gearbox sight glass to ensure reference mark with "S" is perfectly matching the mark at the centre of the hole.
- Set index pointing at degree wheel zero "P.M.S." (TDC).

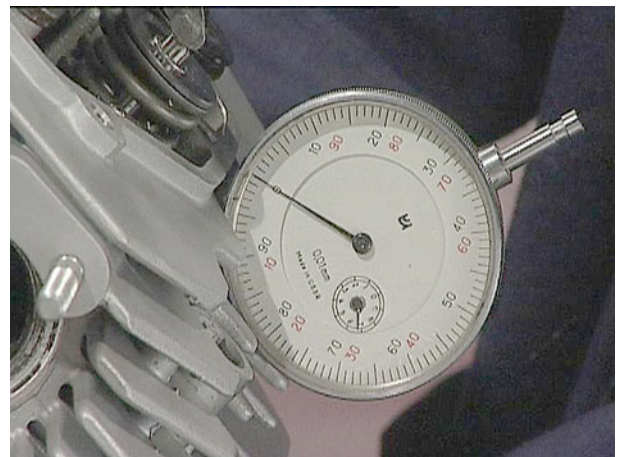
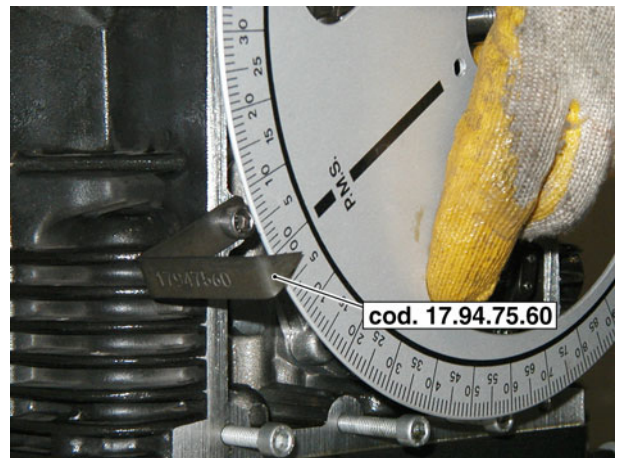
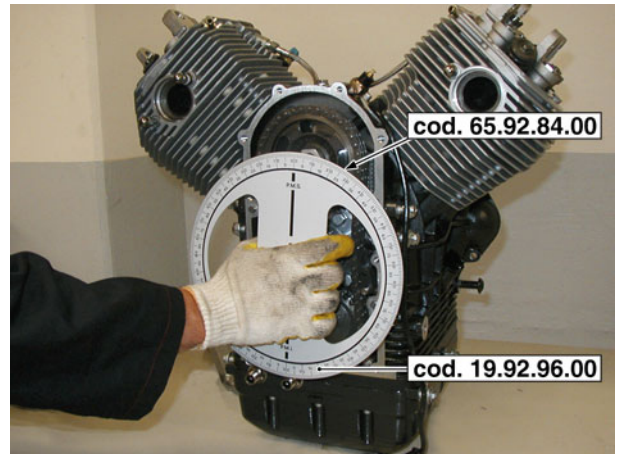

- Check the timing, with reference to timing diagram, considering that:

A – intake starts before TDC  
 B – exhaust ends after TDC  
 C – exhaust starts before BDC  
 D - intake ends after BDC

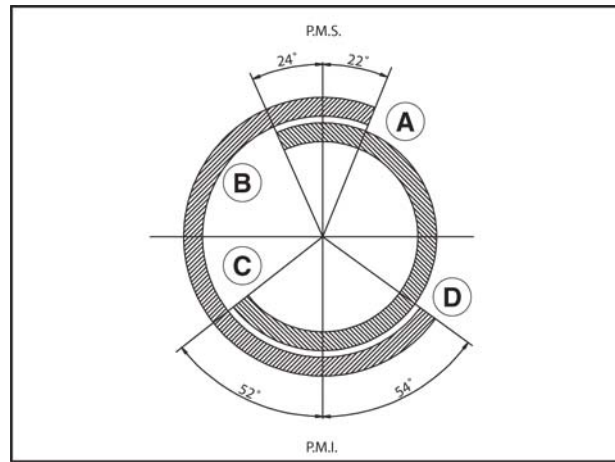

- Tighten the dial gauge and its support on right cylinder external spark plug hole.
  - Secure the index (part no. 17.94.75.60) to the threaded hole to the right of the crankcase using a screw.
  - Turn the degree wheel clockwise until reference "D" matches with the reference at the centre of the gearbox sight glass (valves closed).
  - Repeat the same procedure as previously described for the left cylinder.
- 
- If check shows that everything is fine, set operation clearance between rocker arms and valves [intake 0.10 mm (0.0039 in), exhaust 0.15 mm (0.0059 in)].
  - Remove the degree wheel hub (part no. 65.92.84.00), the degree wheel (part no. 19.92.96.00), the index (part no. 17.94.75.60) and the support with dial gauge.
  - Refit the spark plugs and all parts previously removed.



## Engine V1100

## 3.3.4. MEASURING THE SENSOR GAP

- Loosen and remove the two screws and remove the sensor.



- Fit a suitable flat washer on the sensor, measure its thickness.



- Position the sensor to the timing cover and take it against the pick-up ring.

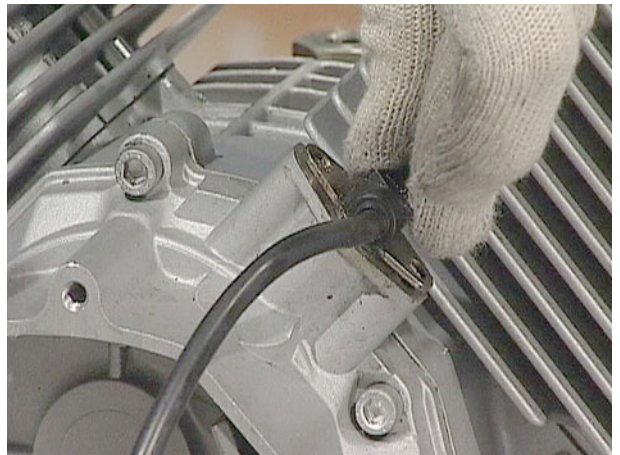

- Measure the clearance between plate and cover using a feeler gauge. Take the flat washer thickness from this value to determine the gap between sensor and pick-up ring.

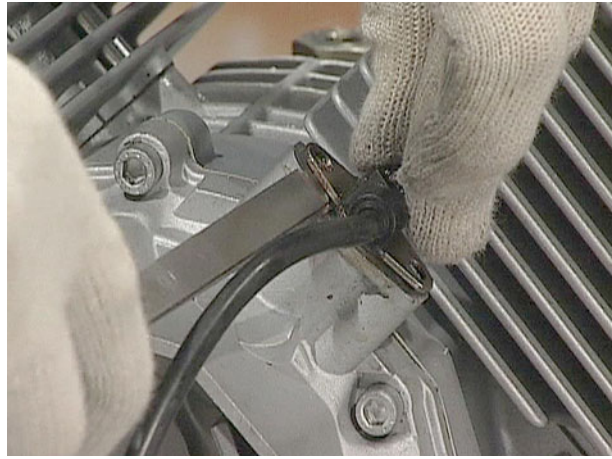

- Remove the washer, smear the plate with suitable sealant, fit the sensor and tighten the screws to the specified torque.

## Engine V1100

**3.4. OIL PUMP****3.4.1. REMOVING THE OIL PUMP**

- Drain all engine oil.
- Remove the generator, see (REMOVING THE GENERATOR).
- Remove the timing system, see (REMOVING THE TIMING SYSTEM).
- Loosen and remove the four oil pump securing screws (A).
- Remove the oil pump (B).

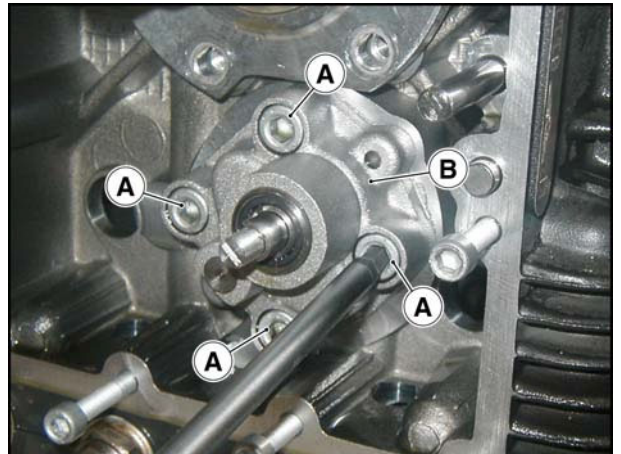

### 3.5. HEADS

#### 3.5.1. REMOVING THE HEAD COVERS

**NOTE** The following procedure applies to both head covers.

- Loosen and remove the eight screws and collect the bushes.

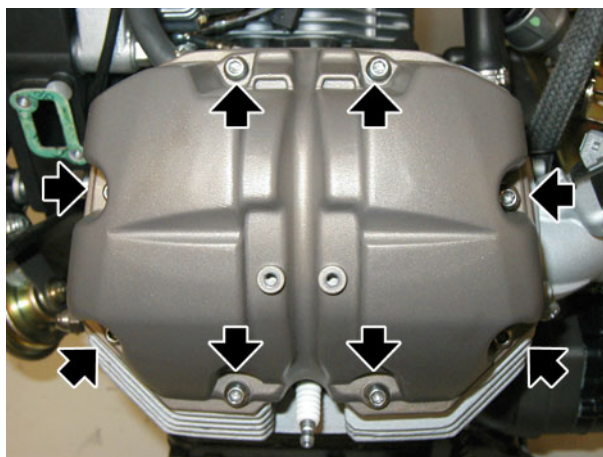

- Remove the head cover and collect the gasket.



**NOTE** Repeat the same procedure above described in reverse order to refit the head cover.

Upon reassembly, change the head cover gasket.



## Engine V1100

## 3.5.2. REMOVING THE HEADS

**NOTE** The following procedure is valid for both cylinder heads.

- Remove the head cover, see (REMOVING THE HEAD COVERS).

- Unscrew and remove the external spark plug.

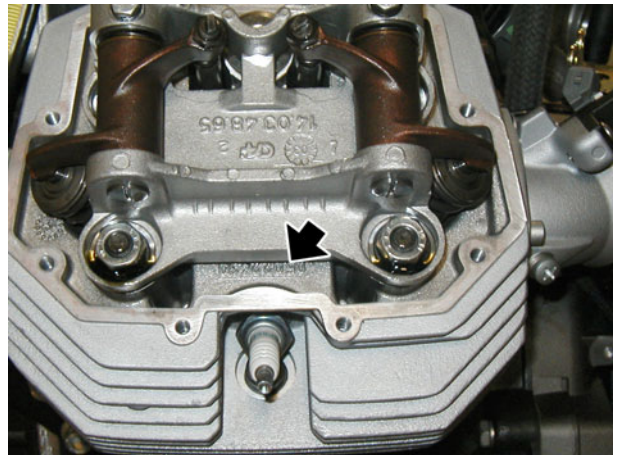

- Turn the crankshaft to set left cylinder to TDC in combustion stage (valves closed).
- Release and remove the two screws.



- Remove the rocker arm shafts.





- Remove the rocker arm and collect the three washers.



- Loosen the nut and disconnect the line delivering oil to the head.



- Loosen and remove the threaded plug.



- Loosen and remove the socket nut and collect the washer.



## Engine V1100

- Loosen and remove the four nuts and collect the relevant washers.

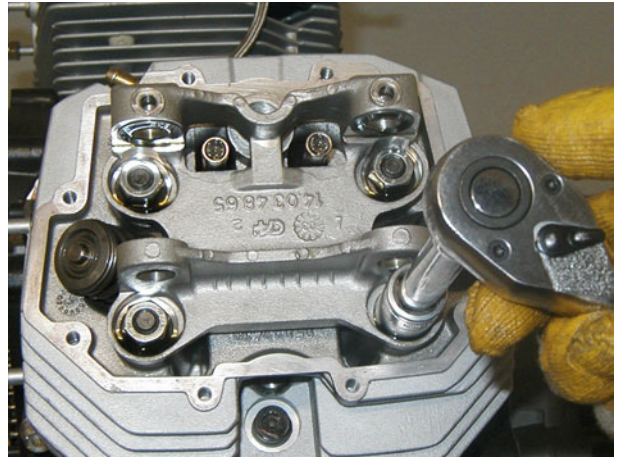

- Remove the rocker arm support.



- Slide out the two rocker arm rods



- Using the suitable special tool (part no. 05.90.19.30), loosen and remove the internal spark plug.





- Loosen and remove the two screws and collect the two washers.

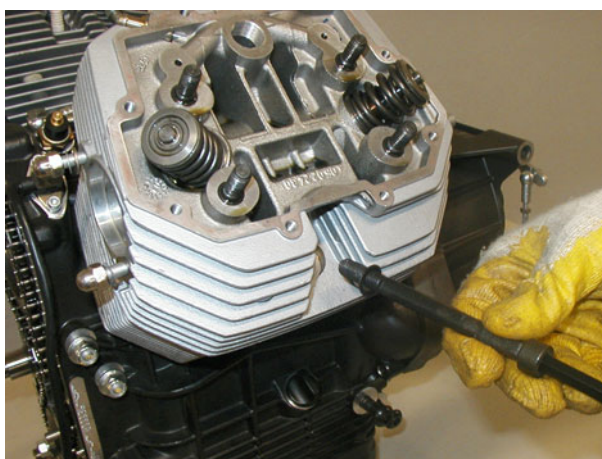

- Slightly detach the head from the cylinder and remove the four O-rings.

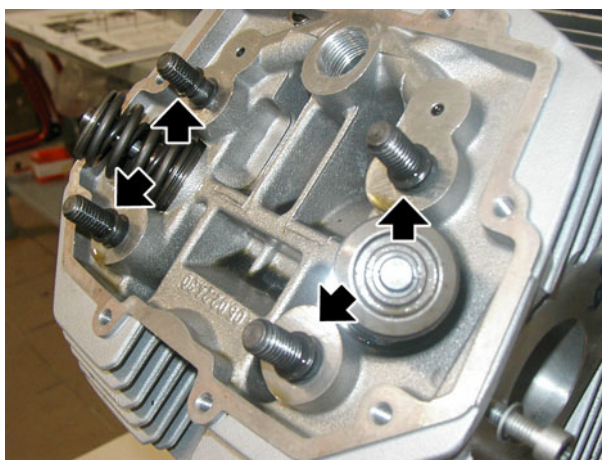

- Slide out the head and collect the gasket.



## Engine V1100

- Fit the special tool (part no. 10.90.72.00) to top retainer and at the centre of the valve to be removed.



- Tighten the tool screw until it starts pulling, then tap with a mallet on tool head (working on top retainer) so to detach the two valve cotters (1) from top plate (2).
- Once the two valve cotters (1) are detached, screw in until they can be removed from their seats on the valves; loosen the tool and remove it.
- Slide out the top retainer (2).
- Remove the internal spring (3).
- Remove the external spring (4).
- Remove the bottom retainer (5) and the shims, if necessary.
- Remove valve (6) from inside the head.

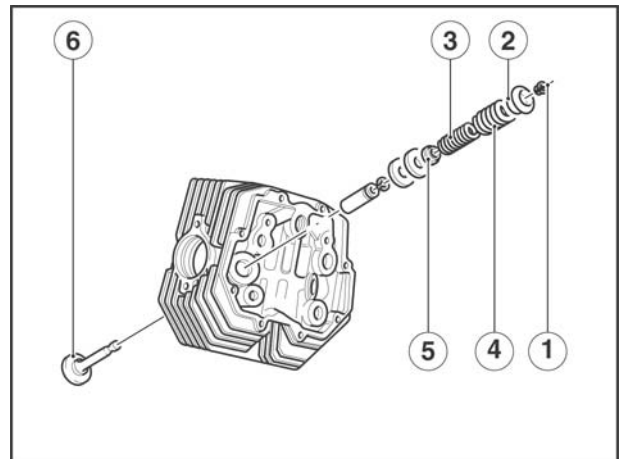

### 3.5.3. CHECKING THE COMPONENTS

#### HEADS

Ensure that:

- Surfaces mating with cover and cylinder are not so scratched or damaged to compromise sealing.
- Check that clearance between valve guide hole and valve stem is within recommended limit.
- Check valve seat condition.

#### VALVE GUIDES

Use a drift to remove the valve guides from the heads.

The valve guides shall be changed only if clearance between them and the valve stem can not be eliminated by changing the valves only.

Proceed as follows to fit the valve guides to the head:

- Heat up the head in an oven to about 60°C (140°F).
- Lubricate the valve guides.
- Fit the circlips.
- Press the valve guides using a drift.
- Using a bore reamer, grind the holes where valve stem slides, taking the inner diameter to the specified value. Interference fit of seat on the head and valve guide should be 0.046 ÷ 0.075 mm (0.0018 ÷ 0.0030 in).

#### VALVE-TO-GUIDE COUPLING

	INNER Ø OF VALVE GUIDE mm (in)	VALVE STEM Ø mm (in)	ASSEMBLY CLEARANCE mm (in)
Intake	8.000÷8.022 (0.3150÷0.3158)	7.972÷7.987 (0.3139÷0.3145)	0.013÷0.050 (0.0005÷0.0020)
Exhaust	8.000÷8.022 (0.3150÷0.3158)	7.965 ÷ 7.980 (0.3136 ÷ 0.3142)	0.020 ÷ 0.057 (0.0008 ÷ 0.0022)

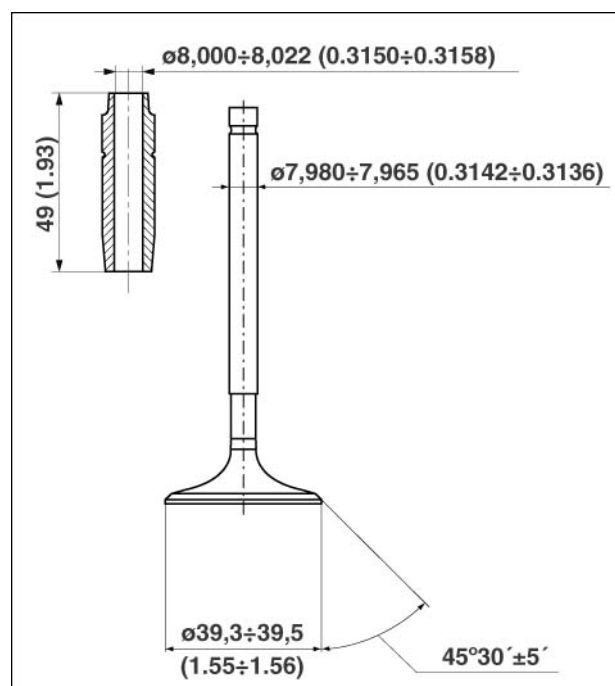
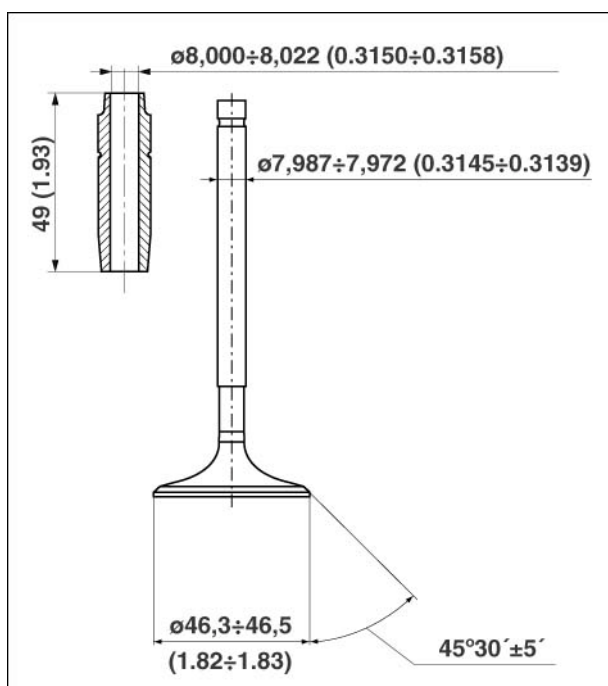

## Engine V1100

## VALVE SEATS

Grind the valve seats with a cutter.

Seat slant angle is  $45^{\circ} \pm 5'$ .

After milling, grind to ensure correct coupling and perfect sealing between valve head and ring nut.

## INTAKE VALVE SEAT DETAIL VIEW

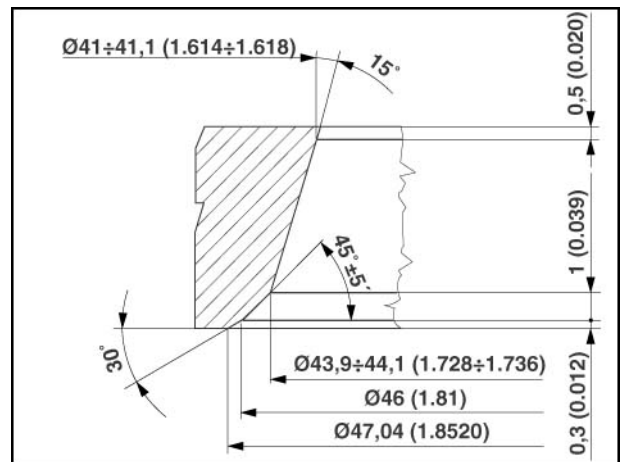

## EXHAUST VALVE SEAT DETAIL VIEW

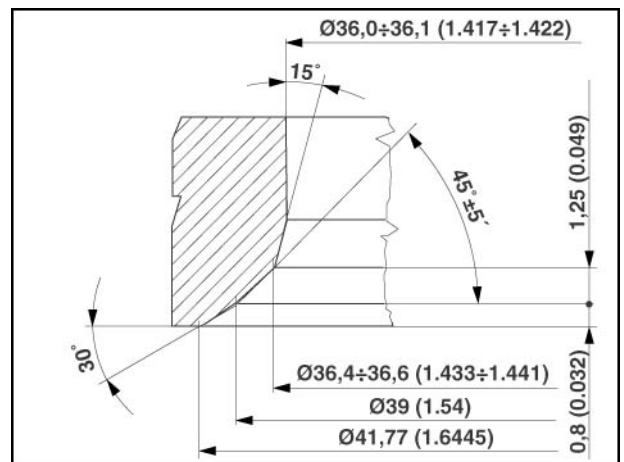



## 3.5.4. REASSEMBLING THE HEADS

**NOTE** The following procedure applies to both cylinder heads.

- Refit valve (6) inside the head.
- Fit the bottom retainer (5) and the shims.
- Refit the external spring (4).
- Refit the internal spring (3).
- Fit the top retainer (2).
- Position the two valve cotters (1) in their seats on the valves.
- Compress the spring with the suitable tool (part no. 10907200), then install the valve cotters.

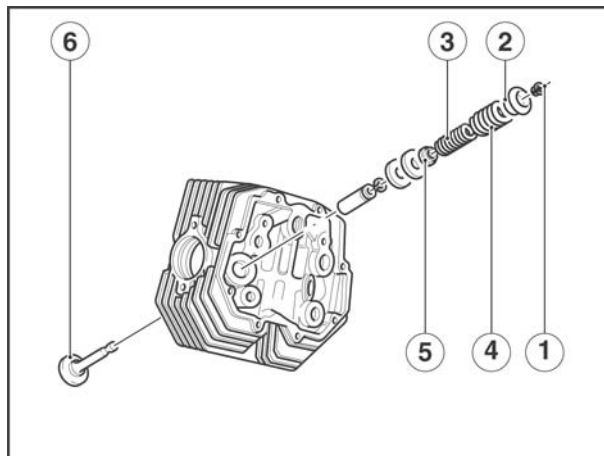

- Remove the special tool (part no. 10.90.72.00)



- Change the cylinder-head gasket.
- Install the head.



- Change the four O-rings.

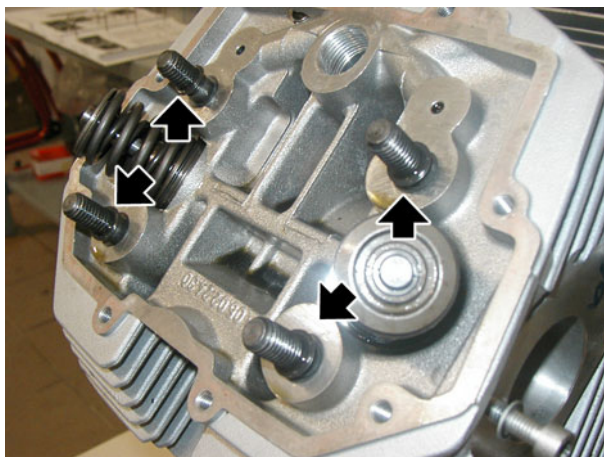

## Engine V1100

- Set the two washers and tighten the two screws.



- Using the suitable special tool (part no. 05.90.19.30), tighten the internal spark plug.



- Install the two rocker arm rods.





- Install the rocker arm support and change the four O-rings.



- Fit the four washers and tighten the four nuts.



- Install the washer and tighten the socket nut.



- Tighten the threaded plug.



## Engine V1100

- Connect the line delivering oil to the head and tighten the nut.

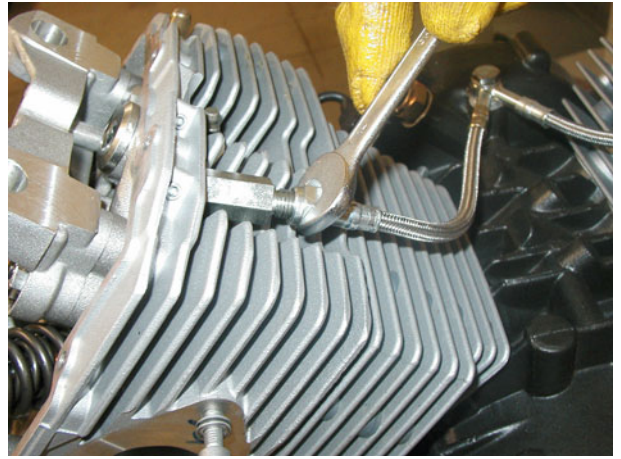

- Fit the six washers and install the rocker arms.



- Install the rocker arm shafts.



- Turn the crankshaft to set left cylinder to TDC in combustion stage (valves closed).
- Tighten the two screws.





- Install the external spark plug.

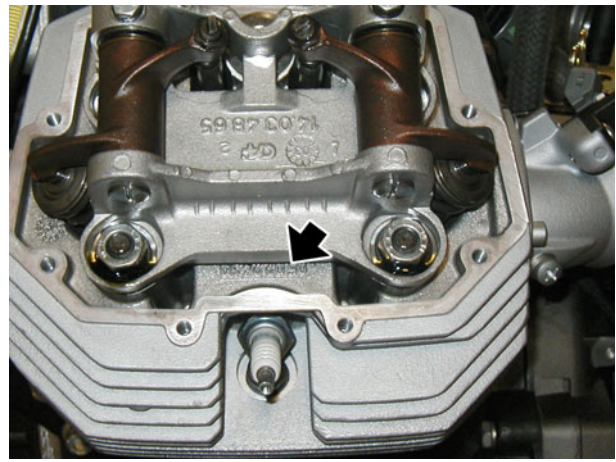

- Change the gasket and install the head cover, see (REMOVING THE HEAD COVERS).



## Engine V1100

**3.6. CYLINDERS AND PISTONS****3.6.1. REMOVAL, CHECK AND INSTALLATION**

*NOTE The following procedure applies to both cylinder heads.*

**REMOVAL**

- Remove the head, see (REMOVING THE HEADS).
- Slide out the gasket.



- Remove the cylinder clear of the stud bolts, do not damage the piston.



- Cover crankcase opening with a clean rag.
- Release gudgeon pin circlip.



- Remove the gudgeon pin.



- Mark the piston crown on exhaust side to ensure correct reassembly.
- Remove the piston.



**CHECK**

**Checking cylinder wear:**

Cylinder diameter is to be measured at three heights, turning the dial gauge by 90°. Ensure that the cylinders and pistons belong to the same class (A,B,C).

**CLASS SELECTION FOR CYLINDER ø UP TO ENGINE NO. KR014485 mm (in)**

CLASS A	CLASS B	CLASS C
92.000÷92.006 (3.62204 ÷ 3.62227)	92.006÷92.012 (3.62227 ÷ 3.62250)	92.012÷92.018 (3.62250 ÷ 3.62275)

**CLASS SELECTION FOR CYLINDER ø UP TO ENGINE NO. KR014486 mm (in)**

CLASS D	CLASS E	CLASS F
92.000÷92.010 (3.62204 ÷ 3.62243)	92.010÷92.020 (3.62243 ÷ 3.62282)	92.020÷92.030 (3.62282 ÷ 3.62322)

**CLASS SELECTION FOR PISTON ø UP TO ENGINE NO. KR014485 mm (in)**

CLASS A	CLASS B	CLASS C
91.954÷91.960 (3.62022 ÷ 3.62046)	91.960÷91.966 (3.62046 ÷ 3.62070)	91.966÷91.972 (3.62070 ÷ 3.62093)

**CLASS SELECTION FOR PISTON ø UP TO ENGINE NO. KR014486 mm (in)**

CLASS D	CLASS E	CLASS F
91.942÷91.952 (3.61975 ÷ 3.62014)	91.952÷91.962 (3.62014 ÷ 3.62054)	91.962÷91.972 (3.62054 ÷ 3.62093)

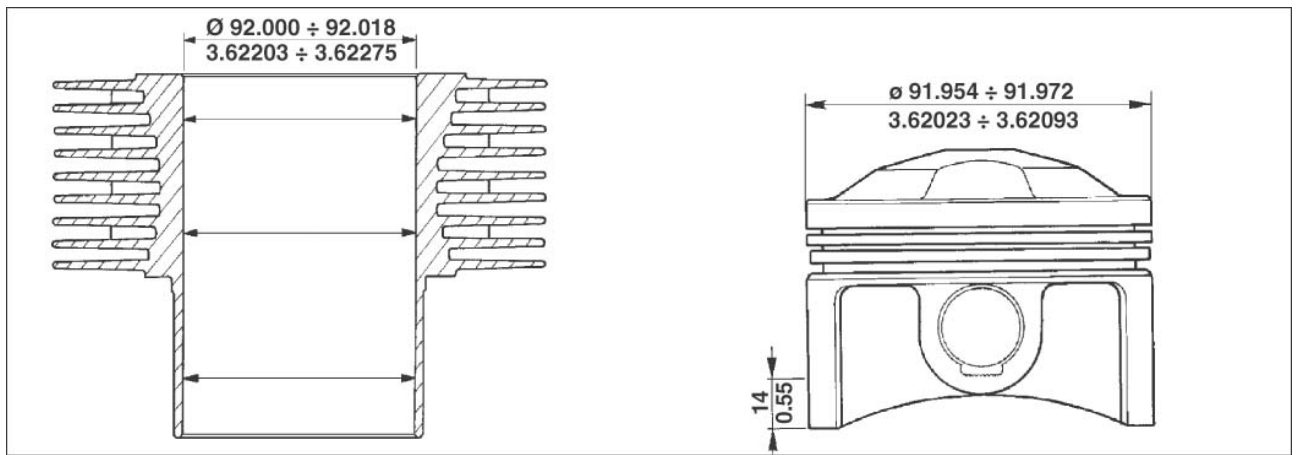

### Checking the pistons

During overhaul, remove scaling from piston crown and ring grooves; check clearance between cylinder and piston on diameter (refer to the relevant class); if it exceeds reference value, change cylinders and pistons.

The pistons of an engine should be balanced; a difference in weight is allowed up to 1.5 grams (0.0033 lb).

Check the piston rings and oil scraper ring.

Every piston fits:

- 1 top ring;
- 1 intermediate ring;
- 1 oil scraper ring.

Piston ring end gaps shall be offset.

Assembly clearance measured between ring thickness and grooves on the piston:

- Sealing rings and oil scraper ring  $0.030 \div 0.065$  mm  
( $0.00118 \div 0.00256$  in)

Gap between the piston ring edges when fitted to the cylinder:

- Top ring and intermediate ring  $0.40 \div 0.65$  mm  
( $0.00158 \div 0.00255$  in)
- Oil scraper ring  $0.30 \div 0.60$  mm ( $0.00118 \div 0.00236$  in)



**INSTALLATION**

*NOTE* The following procedure applies to both cylinder heads.

- Fit the piston

*NOTE* Check piston correct position referring to the reference marks on the piston crown. Never match pistons to cylinders of different classes.



- Fit the gudgeon pin.



- Fit gudgeon pin circlip.



- Remove the rag used to avoid that foreign matter enters the crankcase.
- Turn the piston rings so as the end gaps are at 120 degrees one from the other.
- Lubricate piston and cylinder.
- Using the suitable piston ring compression tool (part no. 05.92.80.30), fit the cylinder.

**WARNING**

During this operation, ensure not to damage the piston.

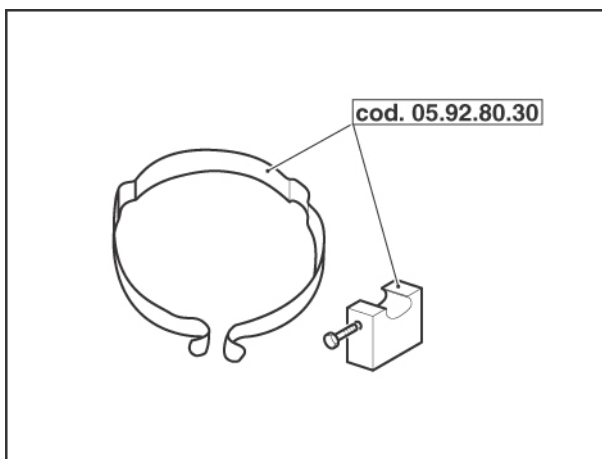



**Engine V1100**

- Remove the piston ring tool (part no. 05.92.80.30) and position the cylinder.



- Fit the gasket at cylinder base.



- Install the head, see (REFITTING THE HEADS).

### 3.7. FLYWHEEL

#### 3.7.1. REMOVAL, CHECK AND REASSEMBLY

##### REMOVAL

- Remove the clutch, see (REMOVING THE CLUTCH).
- Fit the locking tool (part no. 12.91.18.01) to the flywheel and loosen the six flywheel screws; work in a cross pattern and in steps.

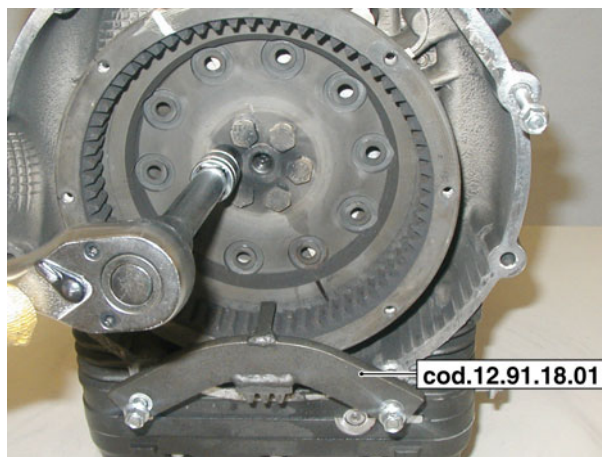

- Remove the flywheel.



##### CHECK

- Ensure that the flywheel mating surface is not scratched.
- Check that surface mating with crankshaft is not deformed; if it is, change the flywheel.

## Engine V1100

## REASSEMBLY

- Perform the removal procedure in reversed order.

**NOTE** Respect flywheel position reference marks.

**WARNING**

Renew the screws upon reassembly since they undergo important stress and load.

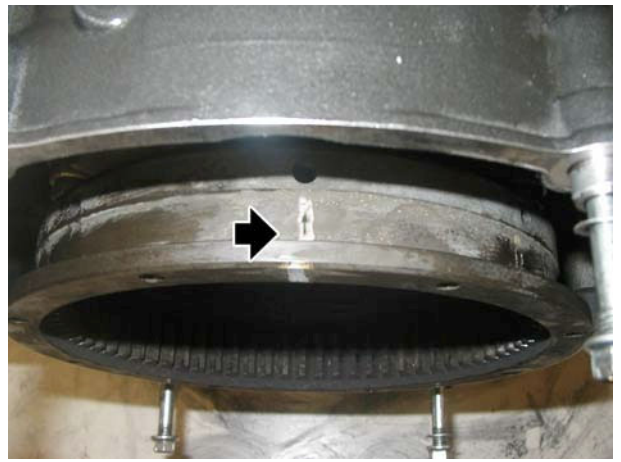

### 3.8. CRANKSHAFT AND CONNECTING RODS

#### 3.8.1. REMOVAL

- Remove the heads, see (REMOVING THE HEADS).
- Remove the cylinders and pistons, see (REMOVAL, CHECK AND INSTALLATION).
- Remove the clutch, see (REMOVING THE CLUTCH).
- Remove the flywheel, see (REMOVAL, CHECK AND REASSEMBLY).
- Remove the timing system, see (REMOVING AND REFITTING).
- Remove the oil sump, see (REMOVAL, CHECK AND REASSEMBLY)
- From inside the crankcase, loosen the jointing bolts (A) and remove the connecting rods (B).

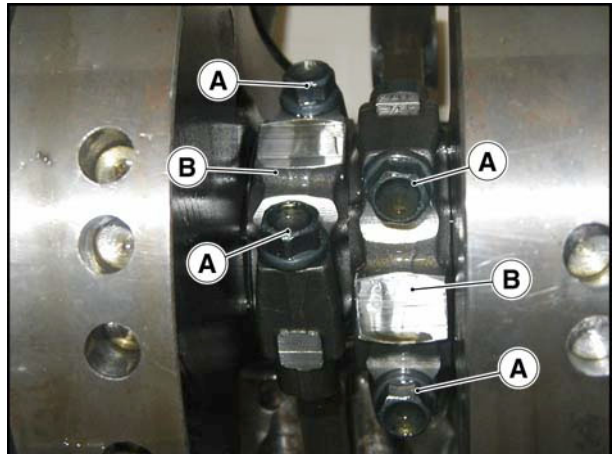

- Loosen and remove the six screws and collect the washers.
- Remove crankshaft flange on generator side.

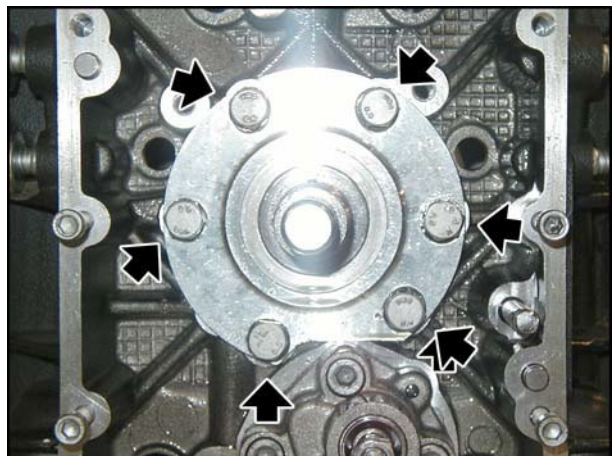

- Loosen and remove the eight screws and collect the washers.

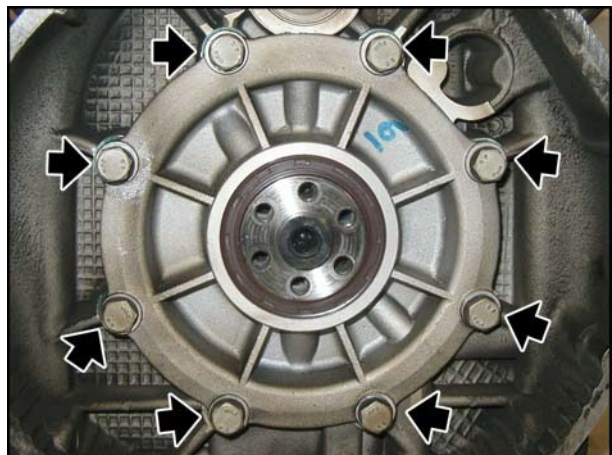



**Engine V1100**

- Using the suitable special tool (part no. 12.91.36.00), remove the crankshaft flange.
- Remove the seal, if necessary.

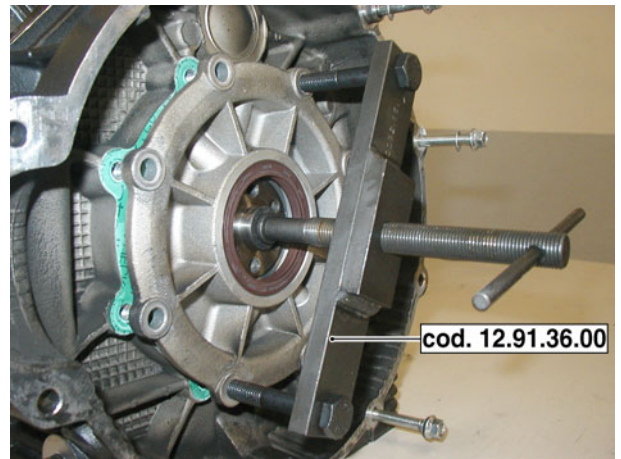

- Slide the crankshaft from the back.





## 3.8.2. CHECK

**WARNING**

During this operation flammable vapours are generated and metal particles might be ejected at high speed, it is therefore recommended to avoid bare flames or sparks in the work place; the operator should wear suitable goggles.

**CONNECTING RODS**

When overhauling the connecting rods, the following checks shall be performed:

- Bushes condition and clearance between bushes and gudgeon pins;
- Axes parallelism;
- Con-rod bearings.

The bearings are of the thin shell type, with antifriction alloy preventing settling; change them in case you notice jamming or wear marks.

When changing the bearings, it might be necessary to grind the crank pin.

Before grinding the crank pin it is recommended to measure its diameter in the more worn area, as shown in the figure, in order to calculate bearing undersize class and to set crank pin final diameter (after grinding).

**Checking axes parallelism.**

Check con-rod straightness before refitting them.

This means that you should check that con-rod big end and small end bores are parallel and coplanar.

Maximum parallelism and alignment error of the two axes of con-rod big and small end measured at a distance of 200 mm (7.873 inch) is  $\pm 0.10$  mm (0.00393 inch).

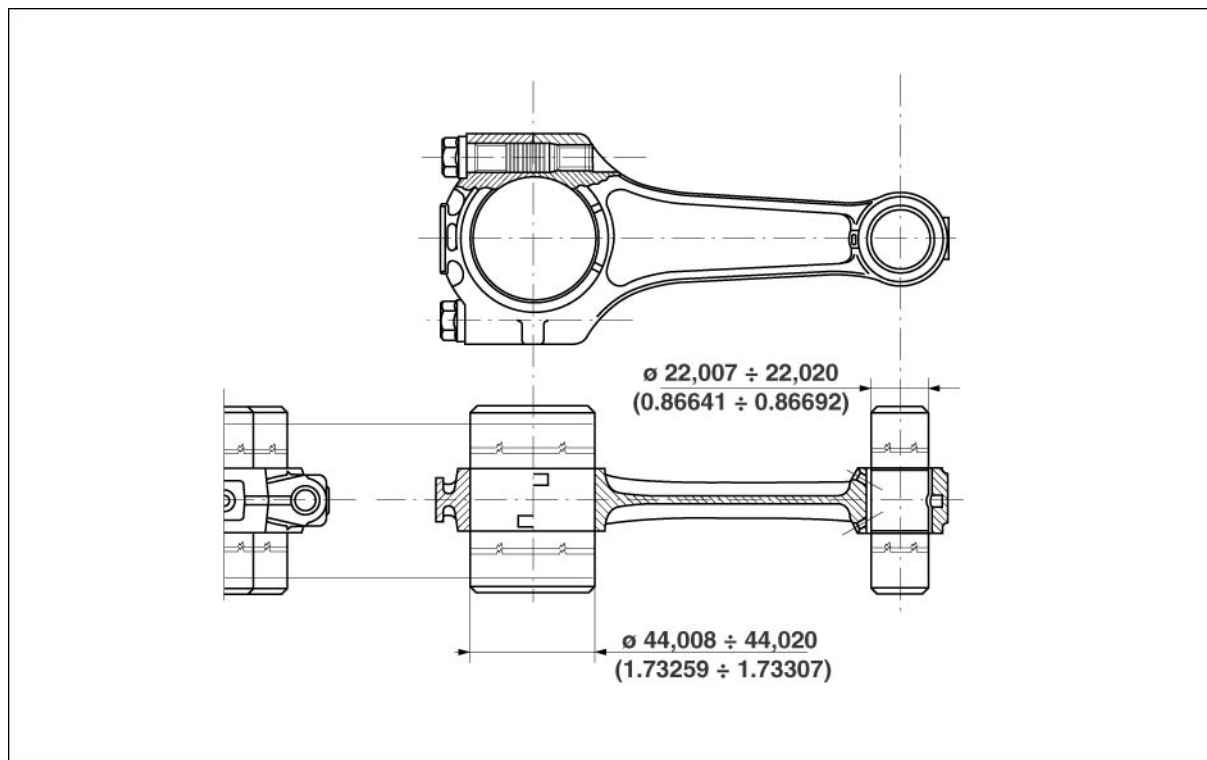

## Engine V1100

**Con-rod bearings thickness**

STANDARD BEARING (PRODUCTION) mm (inch)	Bearings for crank pin $\varnothing$ undersized by mm (inch)		
	0.254 (0.00999)	0.508 (0.01999)	0.762 (0.02999)
From 1.535 (0.06043) to 1.544 (0.06079)	1.662 (0.06543)	1.789 (0.07043)	1.916 (0.07543)
	1.671 (0.06578)	0.798 (0.07079)	1.925 (0.07579)

**Crank pin diameter (B): mm (inch)**

Standard $\varnothing$	Undersized by mm (inch) 0.254 (0.00999)	Undersized by mm (inch) 0.508 (0.01999)	Undersized by mm (inch) 0.672 (0.02645)
44.008 $\div$ 44.020 mm (1.73259 $\div$ 1.73307 in.)	43.754 $\div$ 43.766 mm (1.72259 $\div$ 1.72307 in.)	43.500 $\div$ 43.512 mm (1.71259 $\div$ 1.71307 in.)	43.264 $\div$ 43.258 mm (1.70330 $\div$ 1.70307 in.)

**Gudgeon pin-to-bush coupling**

Inner $\varnothing$ of the bush fitted and machined mm (inch)	gudgeon pin $\varnothing$ mm (inch)	Gudgeon pin-to-bush clearance mm (inch)
22.007 (0.86641) 22.020 (0.86692)	21.994 (0.86590) 21.998 (0.86606)	0.009 $\div$ 0.026 (0.000354 $\div$ 0.001024)

**Connecting rod weight table**

Con-rod total weight g (lb)	Weight of small end side (rotating) g (lb)	Weight of big end side (rotating) g (lb)	Colour of weight selection class
642 $\pm$ 2.5 (1.4153 $\pm$ 0.0055)	165 $\pm$ 1 (0.3638 $\pm$ 0.0022)	476 $\pm$ 3.5 (1.0494 $\pm$ 0.0077)	White
647 $\pm$ 2.5 (1.4263 $\pm$ 0.0055)		479.5 $\pm$ 3.5 (1.0571 $\pm$ 0.0077)	Light blue
652 $\pm$ 2.5 (1.4374 $\pm$ 0.0055)		483 $\pm$ 3.5 (1.0648 $\pm$ 0.0077)	orange

**Crank pin diameter on flywheel side (C)**

STANDARD PRODUCTION mm (inch)	UNDERSIZED BY mm (inch)		
	0.2 (0.0078)	0.4 (0.0157)	0.6 (0.0236)
52.970 (2.08542) 53.951 (2.12405)	53.770 (2.11692) 53.751 (2.11617)	53.570 (2.10905) 53.551 (2.10830)	53.370 (2.10118) 53.351 (2.10042)

**Journal diameter on timing side (A)**

STANDARD PRODUCTION mm (inch)	UNDERSIZED BY mm (inch)		
	0.2 (0.0078)	0.4 (0.0157)	0.6 (0.0236)
37.975 (1.49507) 37.959 (1.49444)	37.775 (1.48720) 37.759 (1.48657)	37.575 (1.47932) 37.559 (1.47869)	37.375 (1.47145) 37.359 (1.47082)

**CRANKSHAFT**

Inspect the journal surfaces; grind them if they are scratched or oval (refer to undersize tables) and change the complete flanges with main bearings.

Undersize values are: 0.2-0.4-0.6 mm (0.0078 – 0.0157 - 0.0236 inch)

Assembly clearance values are:

- Between bearing and journal on timing side 0.028  $\div$  0.060 mm (0.00110  $\div$  0.00236 in);
- Between bearing and journal on flywheel side 0.040  $\div$  0.075 mm (0.00157  $\div$  0.00295 inch);
- Between bearing and crank pin 0.022  $\div$  0.064 mm (0.00087  $\div$  0.00252 inch);

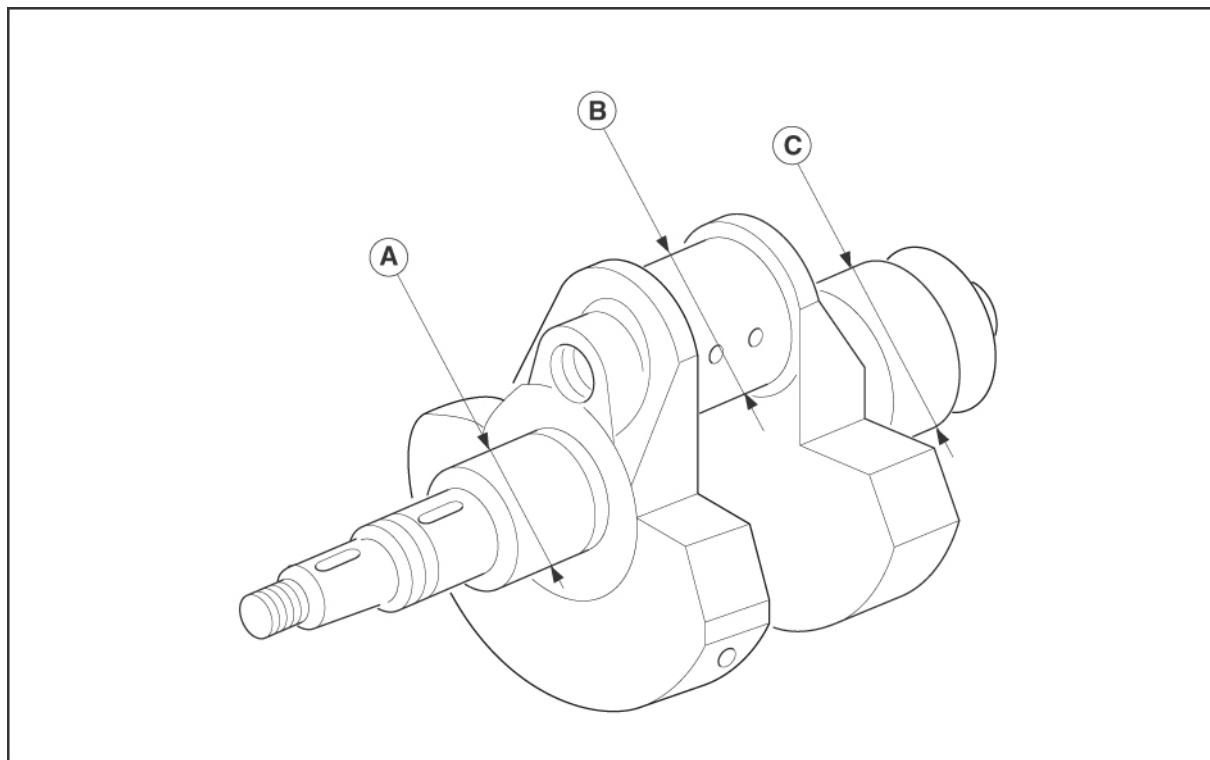
**WARNING**

When grinding the crankshaft pins/journals refer to the shoulder radius value that is:

2.0 ÷ 2.5 mm (0.079 ÷ 0.984 in) for the crank pin,  
3.0 ÷ 3.2 mm (0.118 ÷ 1.260 in) for the journal on  
flywheel side, 1.5 ÷ 1.8 mm (0.059 ÷ 0.071 in) for  
the journal on timing side.

**CHECKING THE WEIGHT FOR CRANKSHAFT  
BALANCING**

The connecting rods with bolts fitted, shall be balanced in weight.

Allowed difference is 4 grams (0.0088 lb).

Apply a weight of 1850 grams (4.0785 lb) to the crankpin to statically balance the crankshaft.

## Engine V1100

## 3.8.3. REASSEMBLY

## CONNECTING RODS

Perform removal instructions in reverse order, consider the following warnings:

- Renew the screws upon reassembly since they undergo important stress and load.
- Assembly clearance between bearing and crank pin is minimum 0.022 mm (0.00087 inch), maximum 0.064 mm (0.00251 inch).
- Clearance between connecting rod shims and crankshaft shims is 0.30 mm (0.01181 inch) ÷ 0.50 mm (0.01968 inch).
- Tighten the bolts on the caps with a torque wrench to the specified tightening torque.

## CRANKSHAFT

- Correctly set the crankshaft support flanges considering their assembly position (indicated by the holes).
- Apply some teflon tape on the two lower rear screws to avoid oil leaks.

- Using the suitable seal tool (part no. 19.92.71.00), install the seal to the flywheel-side flange.

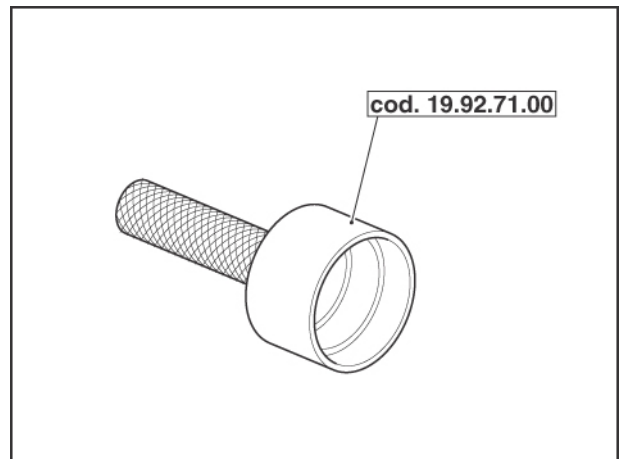

- Hold the camshaft with the suitable tool (part no. 14.92.73.00), and install the flange with seal.
- To complete reassembly, follow the removal procedure in reverse order.

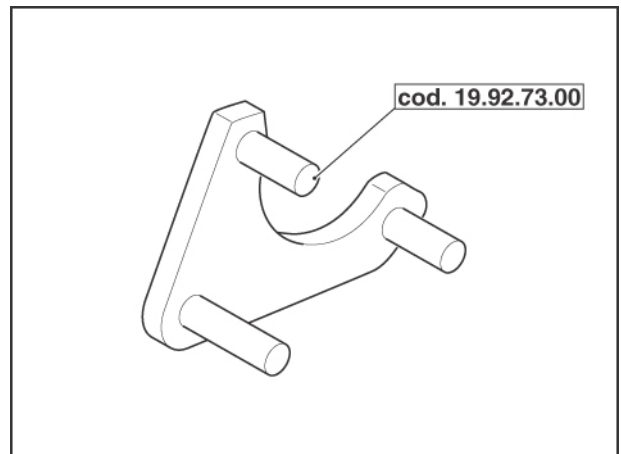

### 3.9. OIL SUMP

#### 3.9.1. REMOVAL, CHECK AND REASSEMBLY

##### REMOVAL

**NOTE** To remove the oil sump it is necessary to set a suitable collector under the sump to collect used oil and drain all oil from the sump.

- If necessary, remove the filter with the suitable special tool (part no. 01.92.91.00).

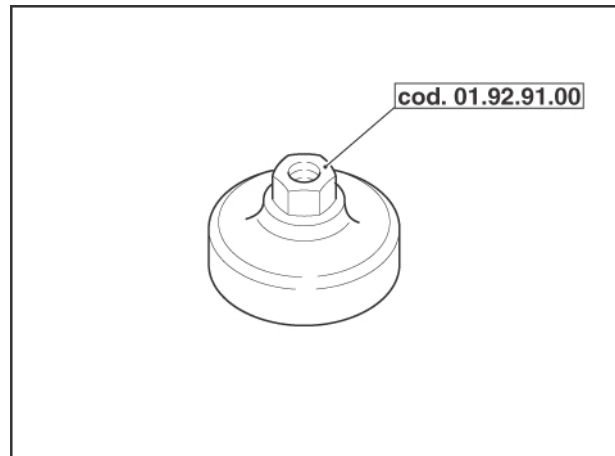

- Loosen and remove oil level plug and collect the O-ring.



- Loosen and remove the fourteen screws securing the oil sump to the crankcase.





## Engine V1100

- Loosen and remove the four screws and remove the black oil sump.



- Release and remove the two screws.

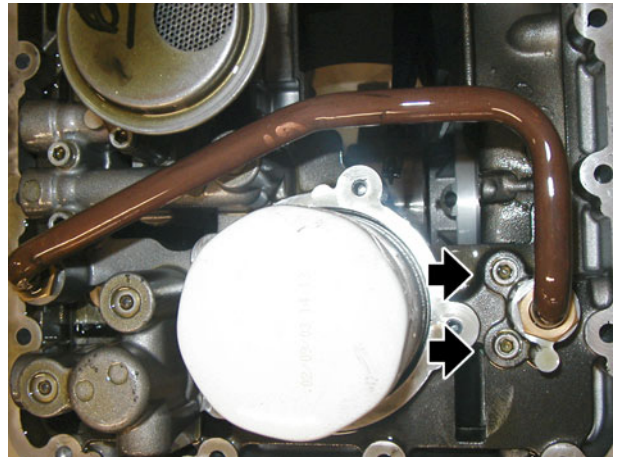

- Release and remove the two screws.
- Remove the mesh filter and collect the gasket.

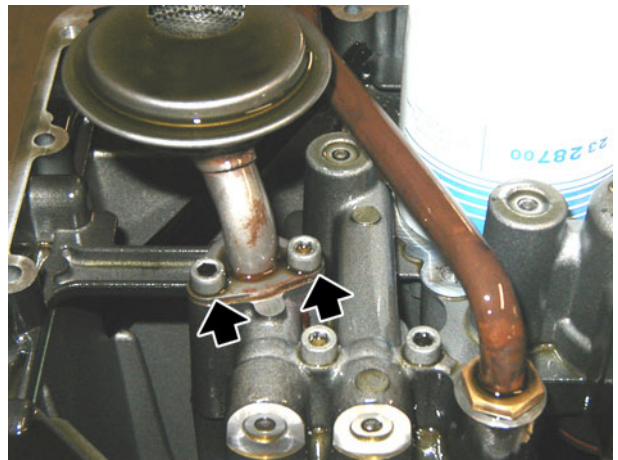

- Remove the black flange and collect the seal.



- Once these parts are removed, it is possible to gain access to the oil pressure control valve and the thermostatic valve. Remove them, if necessary.

**CHECK**

- Check that the mesh filter is not dirty; wash and blow with compressed air, if necessary.

**REASSEMBLY**

- On assembly, perform removal operations in reverse order, remember to change the gasket.

GEARBOX

4

**SUMMARY**

4.1.	GEARBOX .....	3
4.1.1.	DIAGRAM .....	3
4.1.2.	OPENING THE GEARBOX .....	5
4.1.3.	DISASSEMBLING THE PRIMARY SHAFT .....	12
4.1.4.	DISASSEMBLING THE SECONDARY SHAFT .....	14
4.1.5.	DISASSEMBLING THE CLUTCH SHAFT .....	17
4.1.6.	CHECK .....	18
4.1.7.	REASSEMBLY .....	20
4.2.	CLUTCH .....	21
4.2.1.	REMOVING THE CLUTCH .....	21
4.2.2.	CHECKING THE COMPONENTS .....	24
4.2.3.	REFITTING THE CLUTCH .....	25

4.1. GEARBOX

4.1.1. DIAGRAM

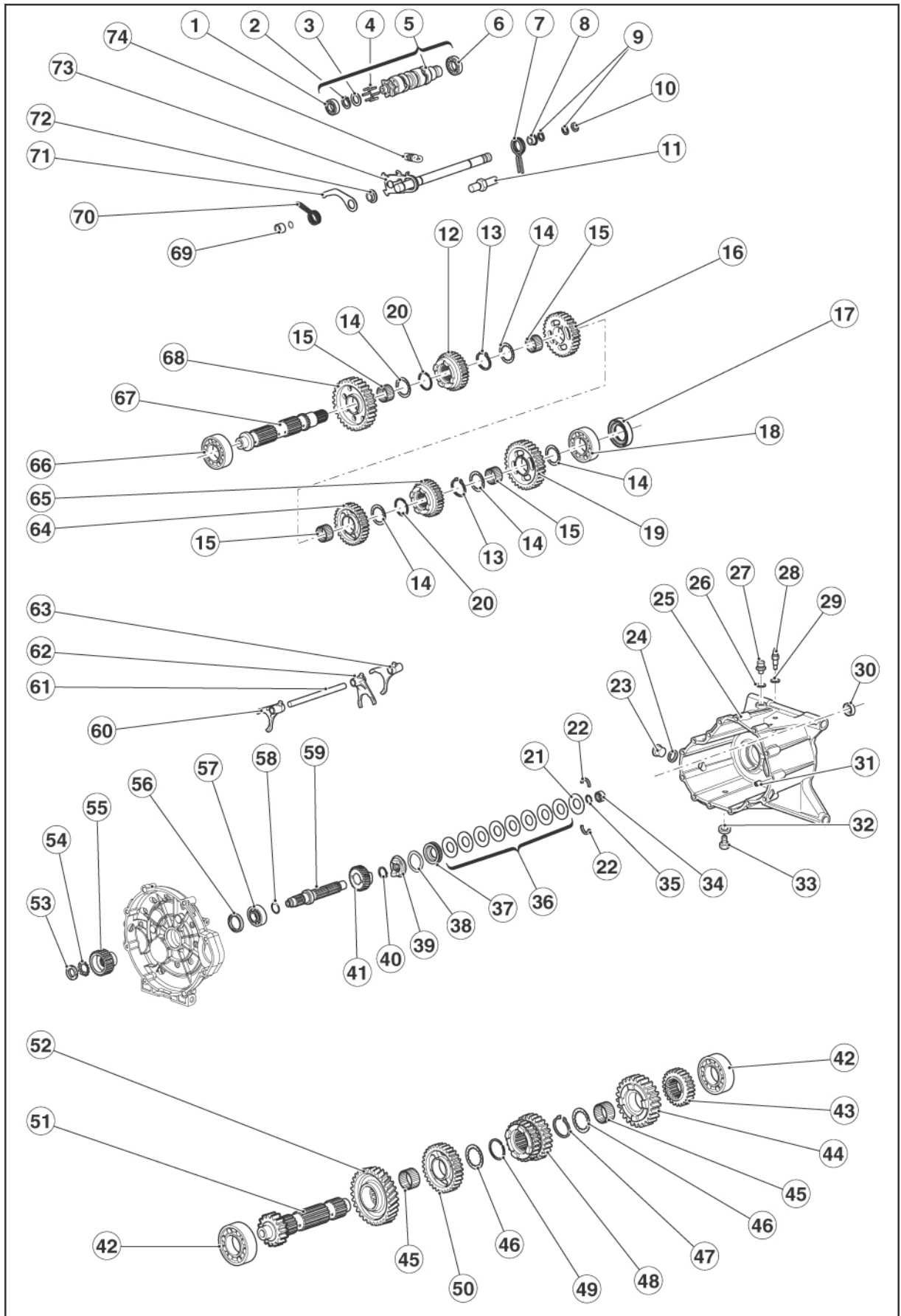



**Key:**

1. Ball bearing
2. Circlip
3. Shim
4. Peg
5. Complete Desmodromic
6. Ball bearing
7. Spring
8. Spacer
9. Circlip
10. Fifth wheel
11. Pin
12. Gear
13. Circlip
14. Washer
15. Roller cage
16. Gear
17. Seal
18. Ball bearing
19. Gear
20. Circlip
21. Retainer
22. Split ring
23. Oil plug
24. Washer
25. Gearbox
26. Aluminium gasket
27. Breather plug
28. Neutral sensor
29. Gasket
30. Seal
31. Bush
32. Gasket
33. Oil drain plug
34. Roller bearing
35. Circlip
36. Belleville washer
37. Spring pusher
38. Shaped washer
39. Sleeve
40. Circlip
41. Idler gear
42. Ball bearing
43. Gear
44. Gear
45. Roller cage
46. Washer
47. Circlip
48. Gear
49. Circlip
50. Gear
51. Primary shaft
52. Transmission gear
53. Ring nut
54. Washer
55. Clutch inner body
56. Seal
57. Ball bearing
58. O-ring
59. Clutch shaft
60. Fork
61. Fork pin
62. Fork
63. Fork
64. Gear
65. Gear
66. Ball bearing
67. Secondary shaft
68. Gear
69. Spacer
70. Spring
71. Index lever
72. Bush
73. Complete preselector
74. Spring

#### 4.1.2. OPENING THE GEARBOX

- Remove the starter motor, see (REMOVING THE STARTER MOTOR).
- Ensure that gearbox is in neutral.
- Loosen and remove the screw and remove the gear shift lever.

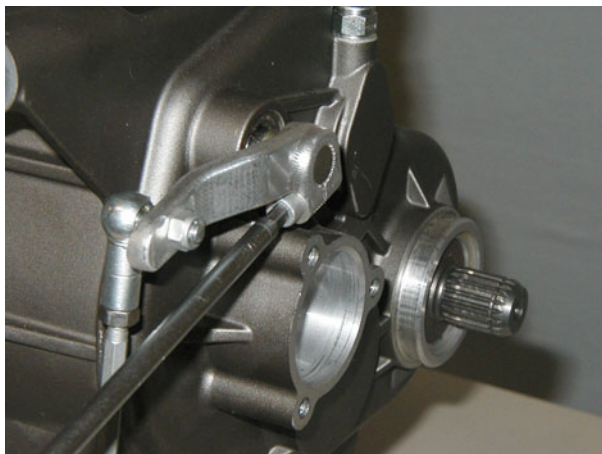

- Loosen and remove the plug.

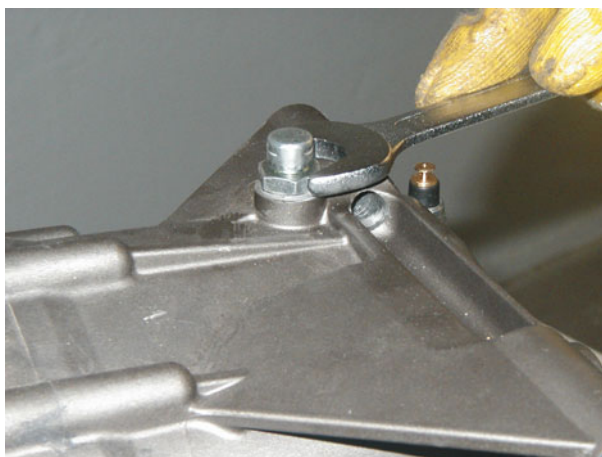

- Set a suitably sized container under it, loosen and remove the plug; drain all oil from gearbox, as described in the reference chassis manual, see (REFERENCE MANUALS).



- Release and remove the three screws.

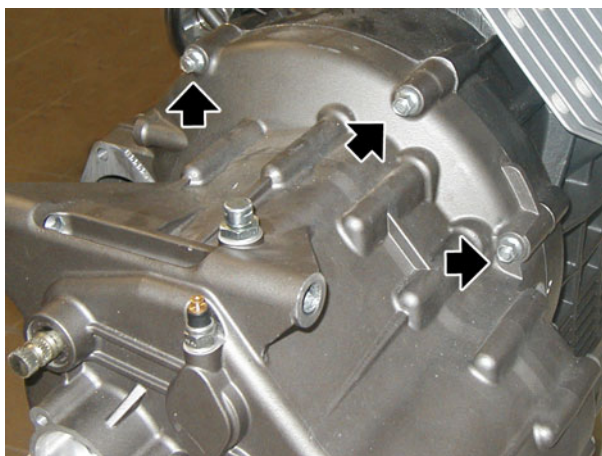

- Release and remove the two screws.



- Unscrew and remove the screw.



- Remove the gearbox.



- Set the gearbox on the suitable gearbox support (part no. 14.92.96.00) and in a vice.

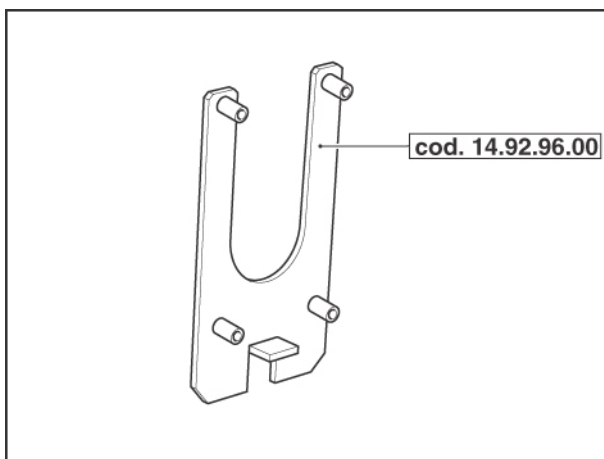



## Engine V1100

- Loosen and slide out the odometer fitment and collect the stop washer that stays inside the gearbox.



- Slide out the cylinder and collect the O-ring and the washer.



- Remove the thrust bearing and cap.



- Slide out the two bushes (1) and remove the rod (2); collect bush (3).

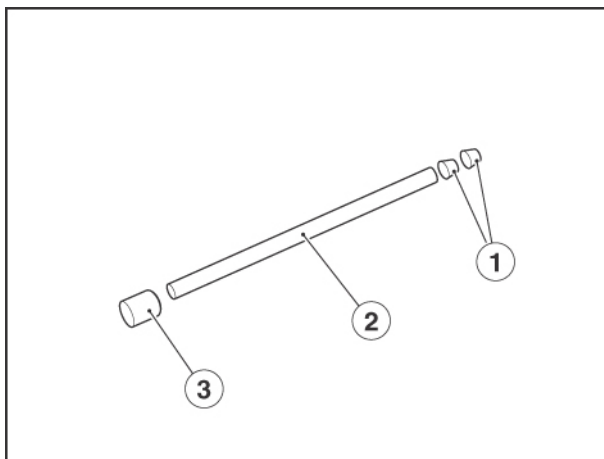

- Bend washer ends.



- Using the suitable pin wrench (part no. 05.91.26.30) and clutch locking tool (part no. 30.91.28.10), loosen and remove the ring nut; collect the inner clutch body.

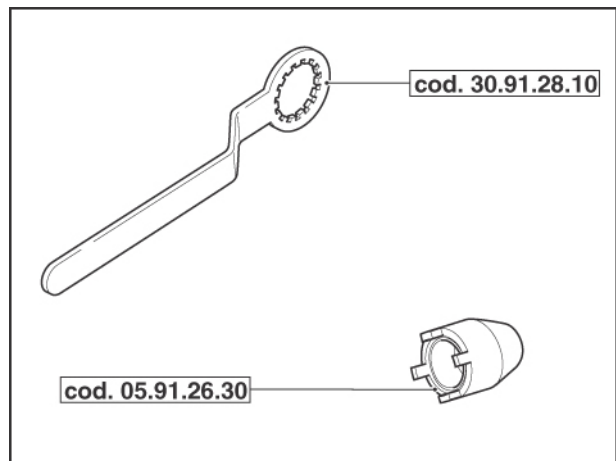

- Using the suitable tool (part no. 05.91.25.30) open the gearbox.

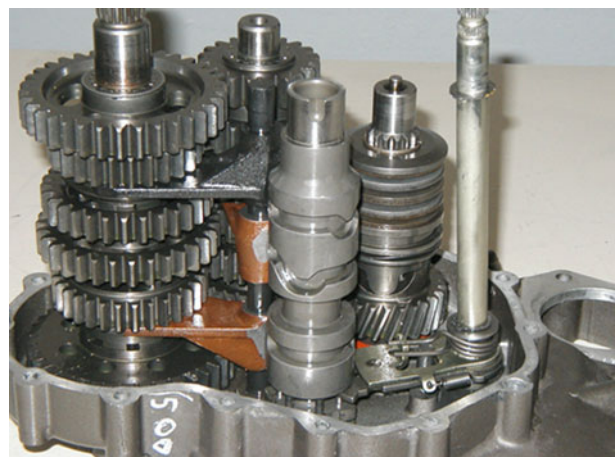
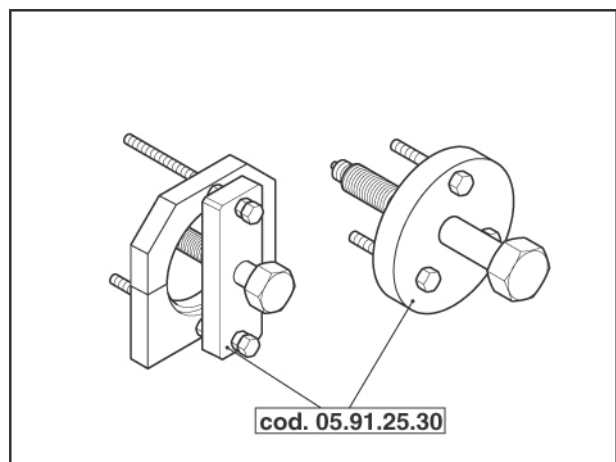



## Engine V1100

- Open the gearbox, see (OPENING THE GEARBOX).
- Release the spring.



- Press on the selector to help removal of the complete transmission lever.



- Loosen and remove the reference threaded pin.

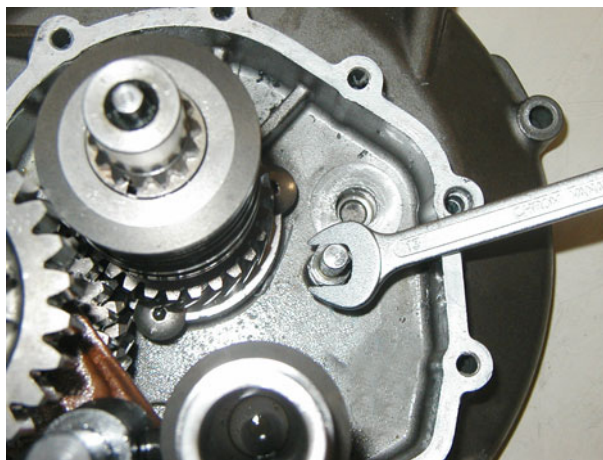

- Use elastic bands to tie the gearbox shafts and remove the unit.

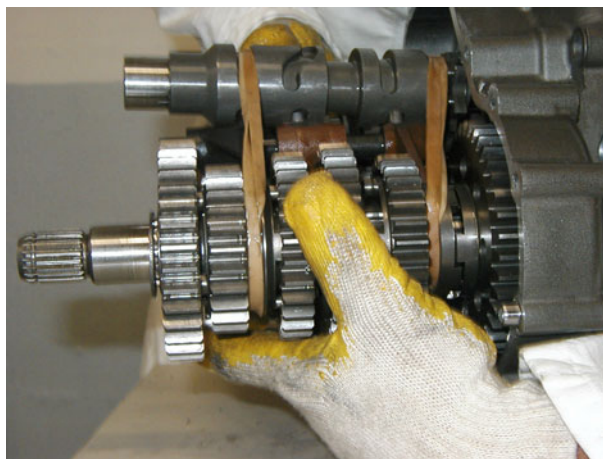

- Remove the bearings from the gearbox.

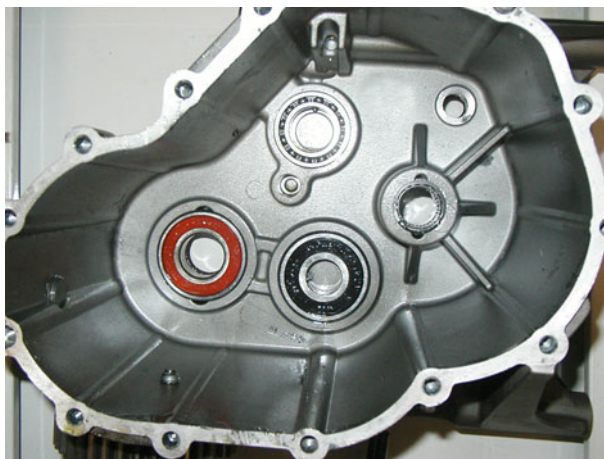

- Set the gearbox shafts on a bench and remove the elastic bands, paying attention not to damage the unit.
- Separate the shafts and mark the forks before removal.



- Slide out the forks and collect the shaft.





- If necessary, change the bearings and remove the clutch shaft.

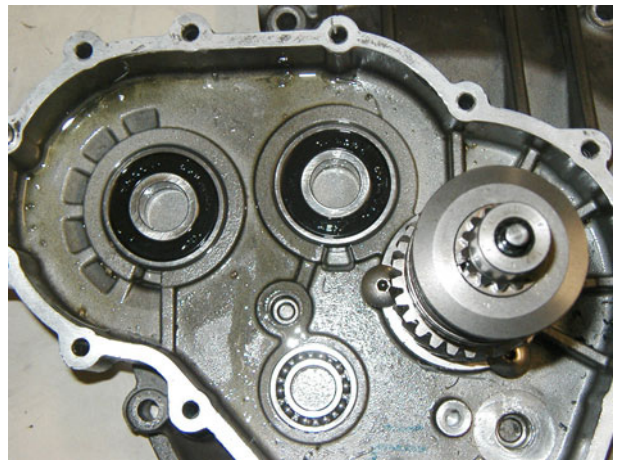



#### 4.1.3. DISASSEMBLING THE PRIMARY SHAFT

- Open the gearbox, see (OPENING THE GEARBOX).
- Work on the primary shaft from the side of the second speed gear.



- Remove the second speed gear, collect the roller cage.



- Remove the sixth speed gear and collect the washer.



- Remove the circlip.



## Engine V1100

- Remove the third and fourth speed gear.



- Remove the circlip and collect the washer.



- Remove the fifth speed gear and collect the roller cage.



- Using a suitable heater, heat up the shaft and remove the transmission helical gear.





**4.1.4. DISASSEMBLING THE SECONDARY SHAFT**

- Open the gearbox, see (OPENING THE GEARBOX).
- Work on the secondary shaft from the splined side.



- Remove the washer.



- Remove the second speed gear and collect the roller cage and the washer.



- Remove the circlip.

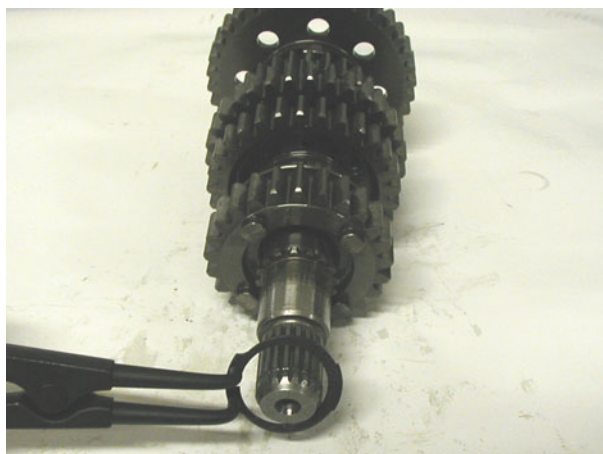

## Engine V1100

- Remove the sixth speed gear.



- Remove the circlip and collect the washer.



- Remove the fourth speed gear and collect the roller cage.



- Remove the third speed gear and collect the roller cage and the washer.



- Remove the circlip.



- Remove the fifth speed gear.



- Remove the circlip, the washer and slide out the first speed gear; collect the roller cage.
- If necessary, remove the bearing.



4.1.5. DISASSEMBLING THE CLUTCH SHAFT

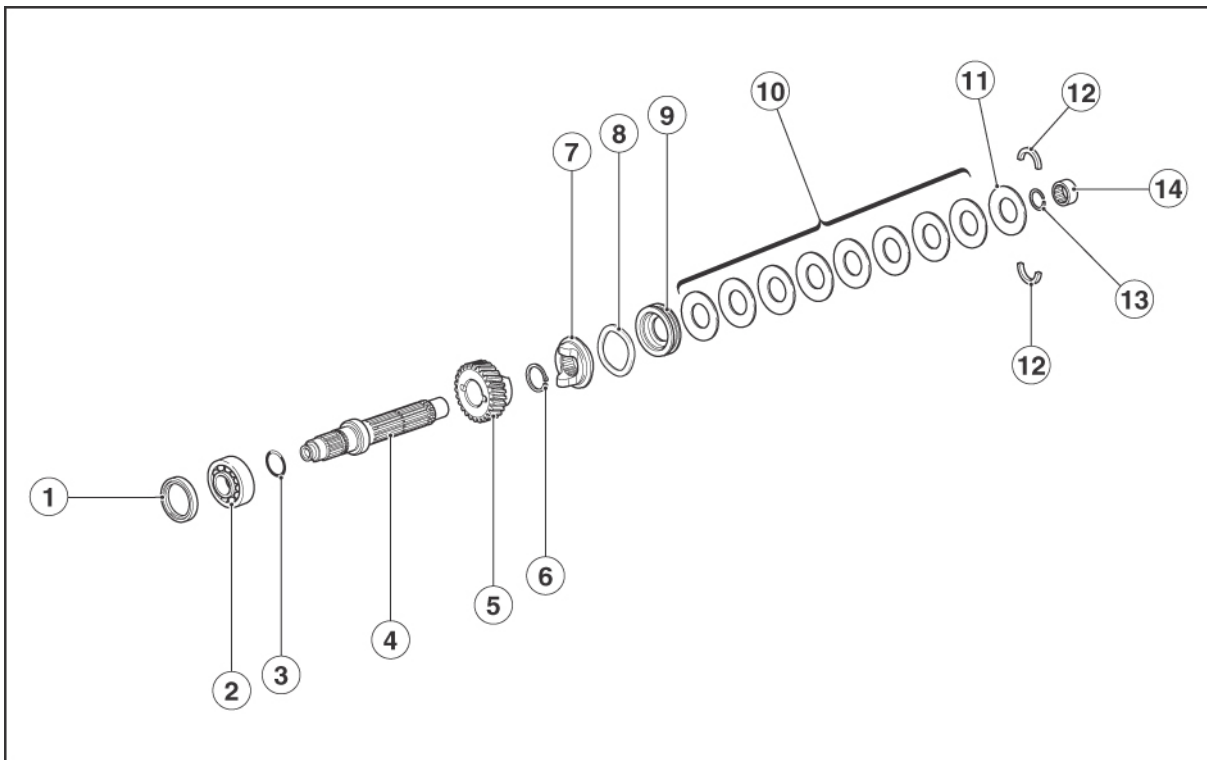

- Open the gearbox, see (OPENING THE GEARBOX).
- If necessary, working on engine side, remove the cover seal (1) and bearing (2); collect the O-ring (3).

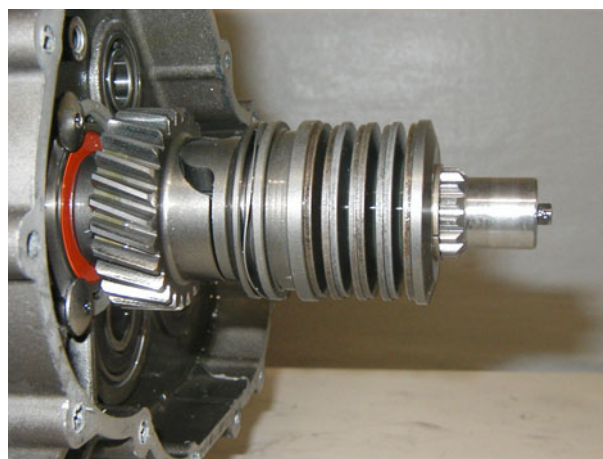

- Working on gearbox side, remove the circlip (13) and the two split rings (12); collect the roller bearing (14).
- Remove retainer (11).
- Carefully remove the Belleville washer (10).
- Remove the spring pusher (9) and collect the shaped washer (8).
- Remove coupling (7).
- Remove the circlip (6).
- Remove the idler gear (5).
- Collect the clutch shaft (4).



## 4.1.6. CHECK

## CHECKING THE GEAR SHIFT FORKS

**NOTE** The following procedure applies to all gear shift forks.

Check the fork cam roller (1) and fork teeth (2) for damages, deformation and wear.  
Change the fork if needed.

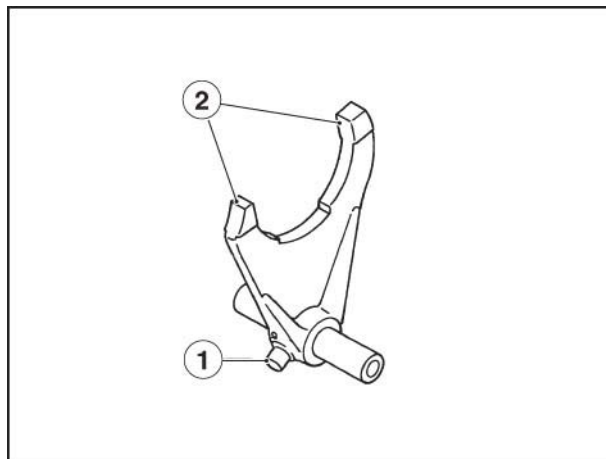

Check fork movement; change the forks if movement is irregular.

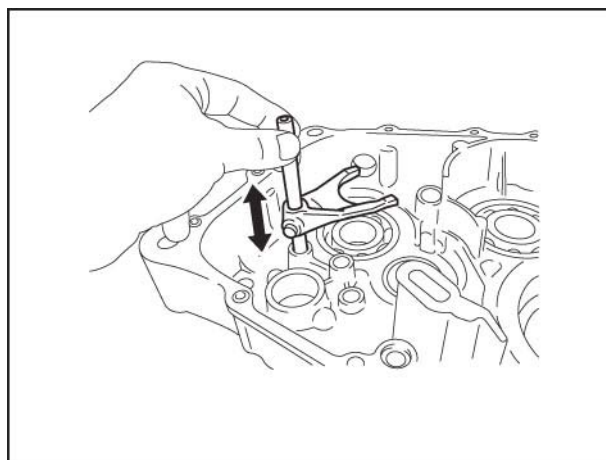

## CHECKING THE DESMODROMIC UNIT

Check gear change drum for damages, scratches and wear marks and possibly change the desmodromic.

Check desmodromic end (3) for damages and wear marks and possibly change it.

Check desmodromic bearing (4) for damages and stains; change the desmodromic if needed.

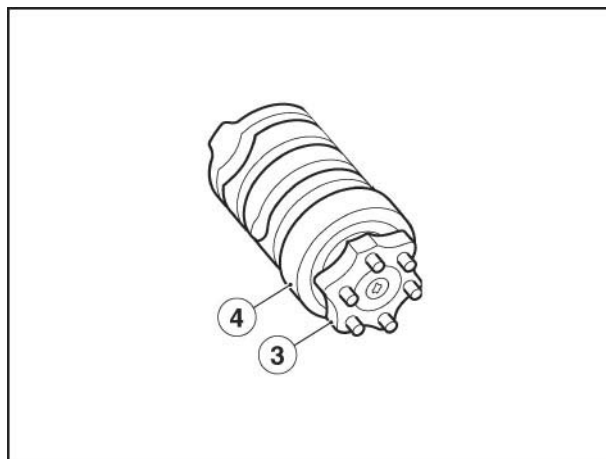



**Engine V1100****CHECKING THE GEARBOX**

Using a gauge and a centring unit, measure primary shaft runout and change it if it does not comply with the specifications.

**Primary shaft limit runout:  
0.08 mm (0.0031 in.)**

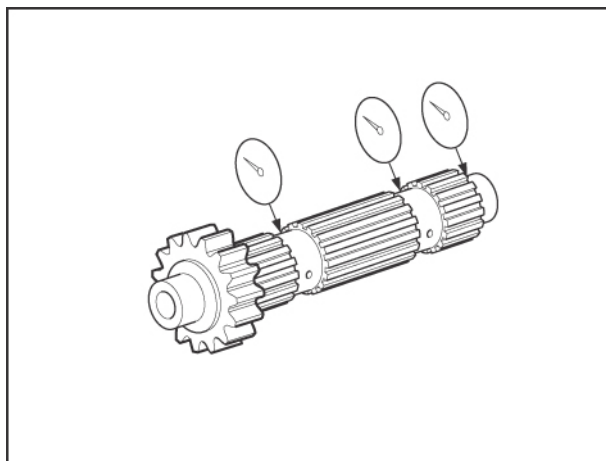

Using a gauge and a centring unit, measure secondary shaft runout and change it if it does not comply with the specifications.

**Secondary shaft limit runout:  
0.08 mm (0.0031 in.)**

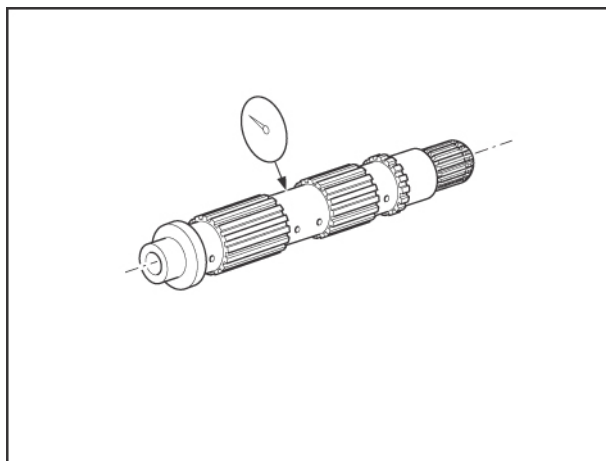

Check transmission gears for stains and wear; change the faulty gears, if needed.

Check gear clutch dogs for cracks, damages and wear marks; change the faulty ones if needed.

Check transmission gear movement, if it is irregular, change the faulty part.

**4.1.7. REASSEMBLY**

**NOTE** For reassembling the clutch shaft, the secondary shaft, the primary shaft and for closing the gearbox, follow the removal instructions in reverse order. Remember to change all seals, circlips and snap rings removed.

## 4.2. CLUTCH

### 4.2.1. REMOVING THE CLUTCH

- Remove the gearbox unit, see (REMOVING THE GEARBOX).
- Fit locking tool (part no. 12.91.18.01) to the flywheel and tool (part no. 30.90.65.10) to compress clutch springs.

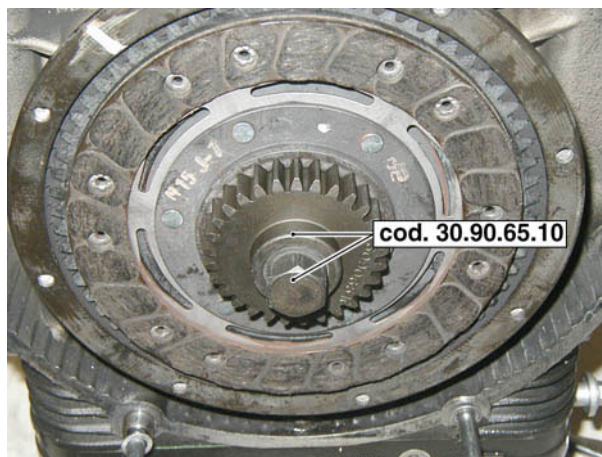

- Loosen and remove the eight screws securing the flywheel gear wheel.

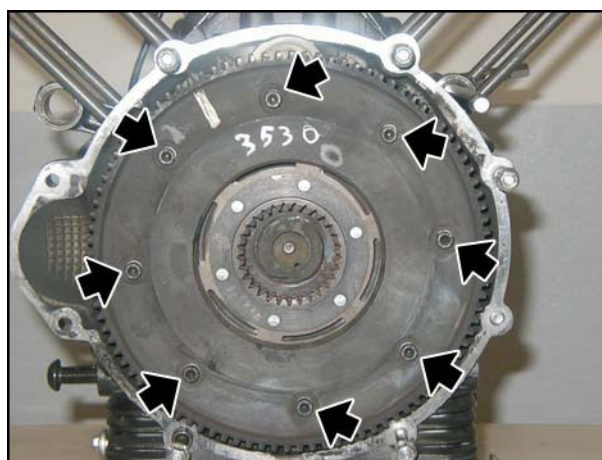

- Remove the gear wheel.



From inside the flywheel, remove:

- the clutch plate;
- the intermediate plate;
- the second clutch plate;
- the pusher plate nut;



**Engine V1100**

- the pusher plate together with springs.





#### 4.2.2. CHECKING THE COMPONENTS

##### Clutch springs

Check that the springs are not yielded or deformed:

- Springs compressed to 22 mm (0.8661 inch) should give a load of 11.25 ÷ 11.70 Kg. (24.80 ÷ 25.79 lb);
- Springs compressed to 20 mm (0.7874 inch) should have a load of 14.75 ÷ 15.30 Kg. (32.52 ÷ 33.73 lb);

##### Spring pusher plate

Check that the plate is not worn at the hole where the retainer works, and that the surface mating with driven plate is perfectly flat.

Check that tothing inside the flywheel is in good condition.

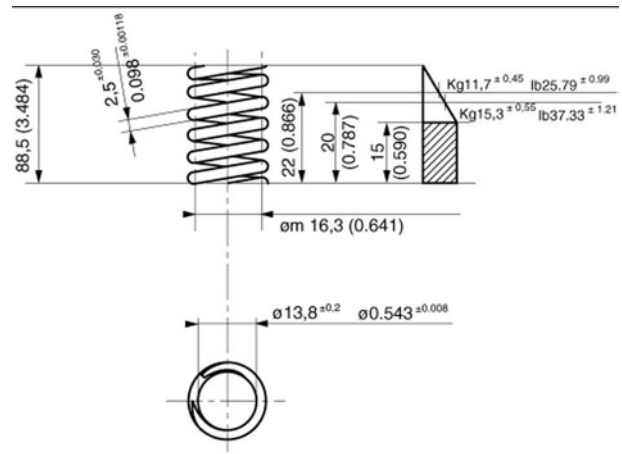

##### Driven plates

Check that the surfaces mating with the driven plates are perfectly smooth and flat and that external teeth working inside the flywheel are not damaged; change the plate, if needed.

##### Starter gear wheel

Check that the surface mating with the driven plate is perfectly smooth and flat.

Also check tothing where starter motor sprocket works, ensure it is not damaged or worn; change the gear if necessary.

##### Clutch inner body

Check that teeth are not worn in the areas contacting with the plates.

### 4.2.3. REFITTING THE CLUTCH

Fit the following parts in the flywheel as follows:

- the spring pusher plate together with springs.
- Ensure that the reference mark on the pusher plate tooth matches the flywheel reference mark.
- Fit the locking tool (part no. 12.91.18.01) to flywheel and tool (part no. 30.90.65.10) compressing the clutch springs.

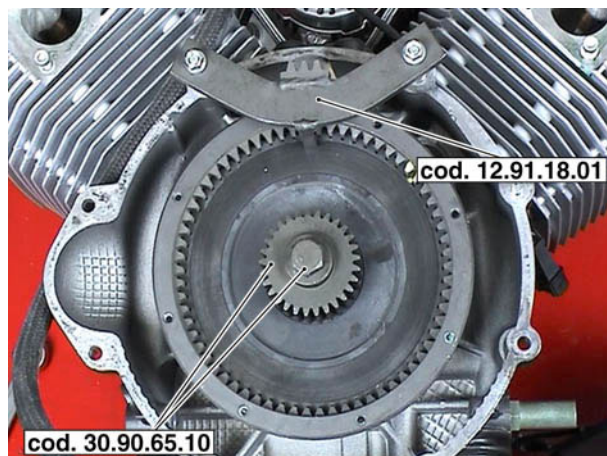
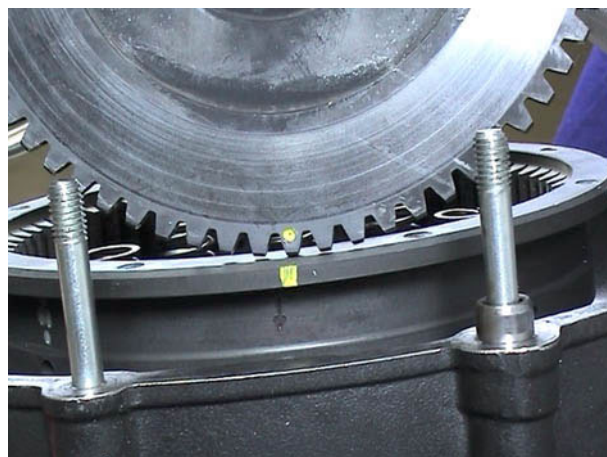
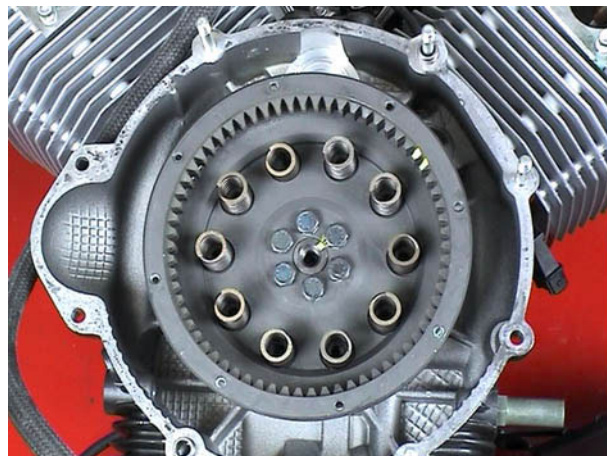

- Remove the locking tool (part no. 12.91.18.01)

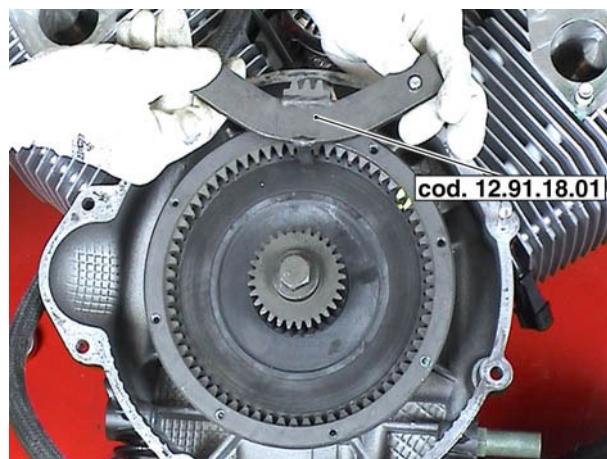

- Fit the clutch plate.

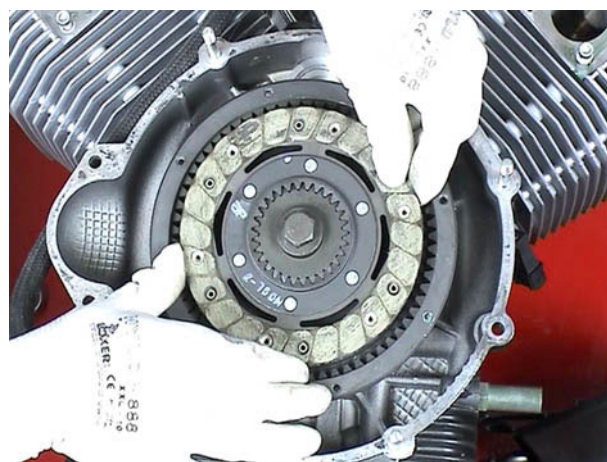

- Fit the intermediate metal plate.

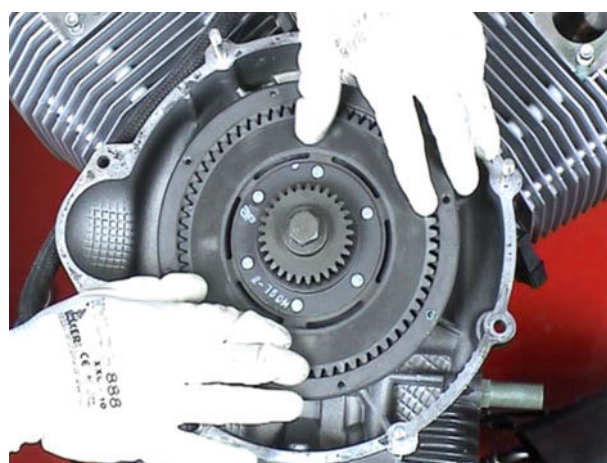

- Fit the clutch plate.

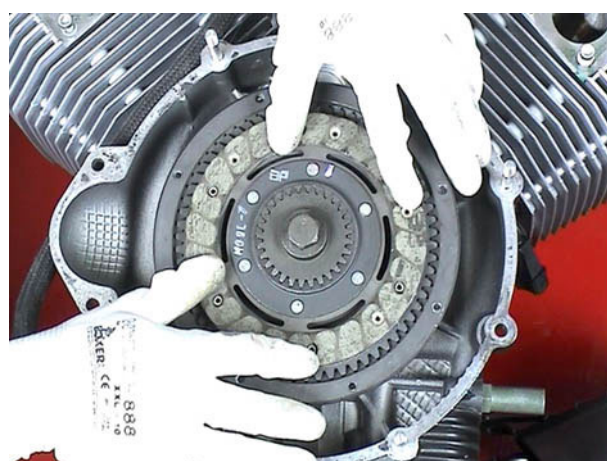



## Engine V1100

- Position the gear wheel aligning the reference mark to the flywheel one.
- Tighten the eight screws securing the gear wheel to the flywheel to the specified torque; proceed in a cross pattern.
- Remove tool (part no. 30.90.65.10) compressing the clutch springs.
- Fit the spring cap.
- Install the gearbox.

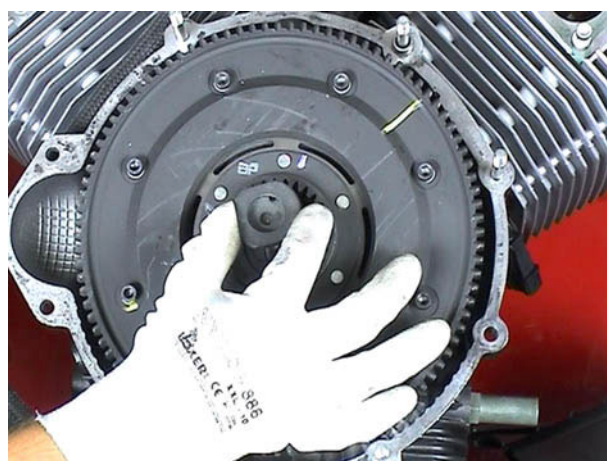
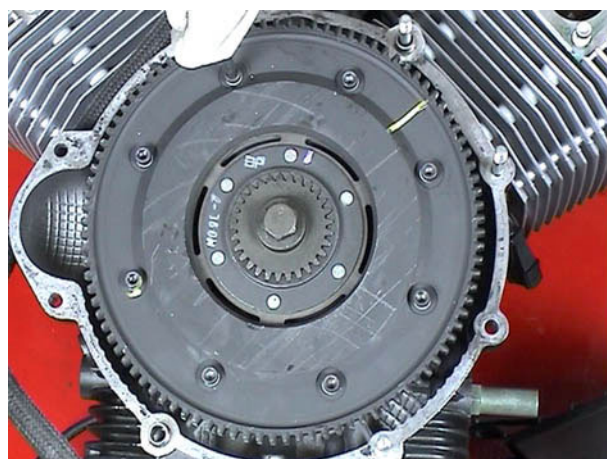
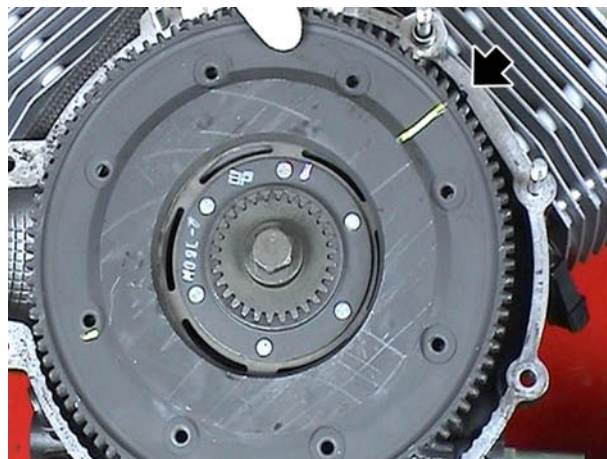

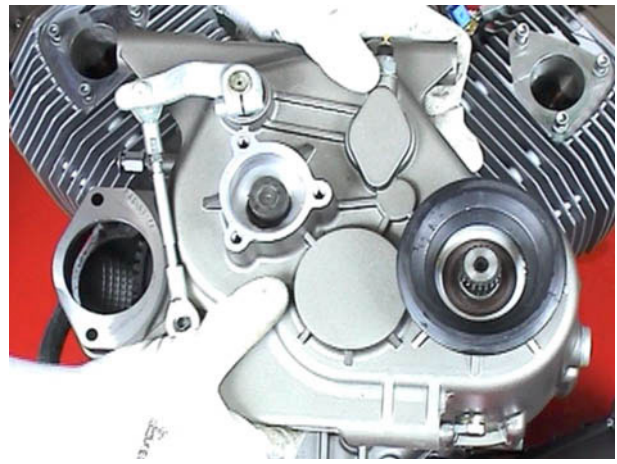





**Moto Guzzi S.p.a.**

Via E.V. Parodi, 57  
23826 Mandello del Lario (LECCO) Italy  
Tel. +39 0341 709111  
Fax +39 0341 709220  
[www.motoguzzi.it](http://www.motoguzzi.it)  
[www.servicemotoguzzi.com](http://www.servicemotoguzzi.com)